OPTICAL

SYSTEMS

DESIGN

OPERATOR MANUAL

OSD2168M SERIES

GIGABIT PoE+ ETHERNET

MEDIA CONVERTER

OPTICAL SYSTEMS DESIGN

INDEX 1

1	TECHNICAL SUMMARY	4
1.1	BRIEF DESCRIPTION	4
1.1.1	OVERVIEW.....	4
1.1.2	APPLICATIONS.....	4
1.1.3	FEATURES AND BENEFITS.....	4
1.2	TYPICAL CONFIGURATION.....	5
1.3	TECHNICAL SPECIFICATIONS	6
1.4	OSD2168M FRONT AND REAR PANELS	7
2	INSTALLATION AND OPERATION	8
2.1	INTRODUCTION.....	8
2.2	INSTALLATION	8
2.2.1	WARNING AND PRECAUTIONS.....	8
2.2.2	OSD2168M DRAWINGS AND DIMENSIONS	9
2.2.3	POWER SUPPLY CONNECTIONS	9
2.2.4	FIXED RJ45 COPPER PORT PIN ASSIGNMENTS	10
2.2.5	LED INDICATORS	10
2.2.6	BASIC CONNECTIONS	11
3	MAINTENANCE	12
3.1	INTRODUCTION	12
3.2	EXTERNAL INSPECTION	12
3.3	ROUTINE MAINTENANCE.....	12
4	WARRANTY	13
4.1	WARRANTY PERIOD.....	13
4.2	REPAIRS.....	13
4.2.1	WARRANTY REPAIRS.....	13
4.2.2	OUT-OF-WARRANTY REPAIRS.....	13
4.2.3	SITE REPAIRS	13
4.2.4	EXCLUSIONS	13
	FIGURE 1: OSD2168M TYPICAL CONFIGURATION.....	5
	FIGURE 2: OSD2168M CONNECTORS.....	7
	FIGURE 3: OSD2168M MOUNTING DIMENSIONS	9
	FIGURE 4: 2168M POWER SUPPLY CONNECTIONS	9
	FIGURE 5: FIXED RJ45 ETHERNET CONNECTOR.....	10
	FIGURE 6: LED INDICATORS.....	10
	FIGURE 7: BASIC CONNECTIONS.....	11
	TABLE 1: TECHNICAL SPECIFICATIONS.....	6
	TABLE 2: DC POWER CONNECTION.....	9
	TABLE 3: LED FUNCTION	10

1 TECHNICAL SUMMARY

1.1 BRIEF DESCRIPTION

1.1.1 OVERVIEW

The OSD2168M is designed to convert between 10/100/1000Base-T copper cabling and 1000Base-Sx fiber cabling. It has one PoE+ RJ45 copper port which provides up to 25.4W and one optical port for operation over two fibers. Jumbo frames are also supported by the OSD2168M.

The unit operates on 850nm wavelength over multimode fiber. Operation over at least 550m of OM or OM3 multimode fiber limited by the fiber bandwidth.

A major benefit of the OSD2168M is its reliable operation over the -10°C to +55°C temperature range which allows it to be used in all commercial and many industrial environments.

1.1.2 APPLICATIONS

- ▲ Any network utilising a mix of copper and fiber
- ▲ Secure, noise immune extensions of gigabit Ethernet backbone networks
- ▲ Commercial IP communications
- ▲ Networks with PoE+ devices such as cameras, WiFi hotspots, etc

1.1.3 FEATURES AND BENEFITS

- ▲ Complies with IEEE802.3i/802.3u/802.3ab 10/100/1000Base-T, IEEE802.3z 1000Base-Sx standards.
- ▲ Supports network traffic of up to 1000Mbps.
- ▲ Has one fixed 10/100/1000BaseT copper port and one fixed 1000BaseSx optical port
- ▲ Automatic MDIX: no need for crossover cables.
- ▲ Complies with the IEEE802.3az Energy-Efficient Ethernet standard
- ▲ Provides up to 25.4W PoE
- ▲ Complies with the IEEE802.3af and IEEE802.3at standards
- ▲ Supports jumbo frames of up to 10KB
- ▲ Multimode fiber operation
- ▲ Available for operation over 2 fibers
- ▲ Powered by a 50 to 56V_{DC} power supply
- ▲ Operates over the temperature range of -10 to +55°C

OPTICAL SYSTEMS DESIGN

1.2 TYPICAL CONFIGURATION

Figure 1 below indicates a typical set-up for an OSD2168M system.

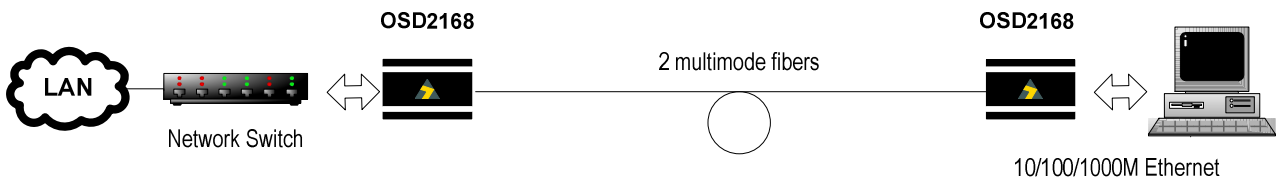

FIGURE 1: OSD2168M TYPICAL CONFIGURATION

OPTICAL SYSTEMS DESIGN

1.3 TECHNICAL SPECIFICATIONS

TABLE 1: TECHNICAL SPECIFICATIONS

SPECIFICATION	PERFORMANCE
Electrical Data Interface	IEEE802.3i/802.3u/802.3ab 10/100/1000Base-T Ethernet
Electrical Data Rate	10, 100, 1000Mbps with energy detect, auto negotiate, auto MDIX
Optical Data Interface	IEEE802.3z 1000Base-Sx
Optical Data Rate	1000Mbps
Operating Mode	Half or full duplex for 10/100 Full duplex for 1000 Pause frames for 1000Mbps flow control
Copper Data Connector	RJ45
Power Over Ethernet	Up to 25.4W per IEEE802.3at
PoE Pin Assignment	4/5 (+) and 7/8 (-)
Optical Connectors	SC
Large Frame Support	10KB
Transmitter Wavelength	850nm
Transmitter Optical Power	-9 to -3dBm into 50/125um multimode fiber (OM2, OM3, OM4) -6 to 0dBm into 62.5/125um multimode fiber (OM1)
Receiver Sensitivity	<-17dBm
Receiver Saturation	>0dBm
Multimode Fiber Link Budget	>8dB: >550m on OM2 or OM3 multimode limited by fiber bandwidth
Dimensions (mm)	60W x 94D x 26H
Weight	0.3kg (module)
Power Requirements	-50 to -56V _{DC} @ 4W plus up to an extra 33W for PoE operation (attached powered device dependant)
Power Connector	Male jack suitable for standard 2.1mm/5.5mm power plugs such as Switchcraft S761K or equivalent
Operating Temperature	-10°C to +55°C
Relative Humidity	0 to 95% non-condensing
Mean Time Between Failures	>400,000 hours at 25°C, Ground Benign Environment per MIL-HDBK-217F

1022216801

OPTICAL SYSTEMS DESIGN

1.4 OSD2168M FRONT AND REAR PANELS

There is one fixed copper port for 10/100/1000Base-T and one SC 1000Base-Sx optical port on the front panel. The rear panel consists of a 2-way terminal block power connector. Each section will be described further throughout this manual.

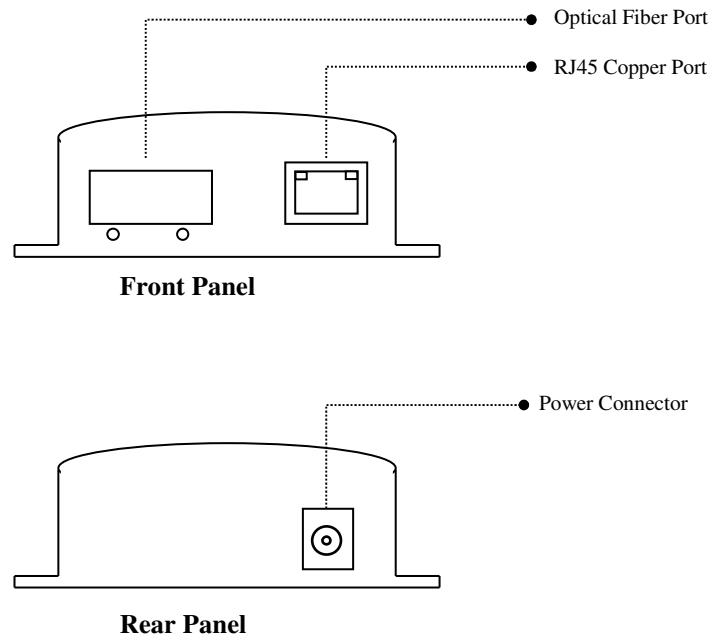

FIGURE 2: OSD2168M CONNECTORS

2 INSTALLATION AND OPERATION

2.1 INTRODUCTION

This section outlines the methods required to install and operate the OSD2168M successfully. It should be studied carefully if damage to the equipment or poor results are to be avoided.

This equipment has been fully tested prior to dispatch and is ready for immediate operation. However it is advisable to check for external transportation damage before operation. If damage is evident, return the unit with the packaging to your supplier immediately.

2.2 INSTALLATION

2.2.1 WARNING AND PRECAUTIONS

▲ ELECTROMAGNETIC COMPATIBILITY

WARNING: This is a Class A product. In a domestic environment this product may cause radio interference in which case the user may be required to take adequate measures.

▲ OPTICAL OUTPUT OPERATION

WARNING: Laser Safety: Class 1 Laser Product per IEC/EN 60825-1:2014 standard.

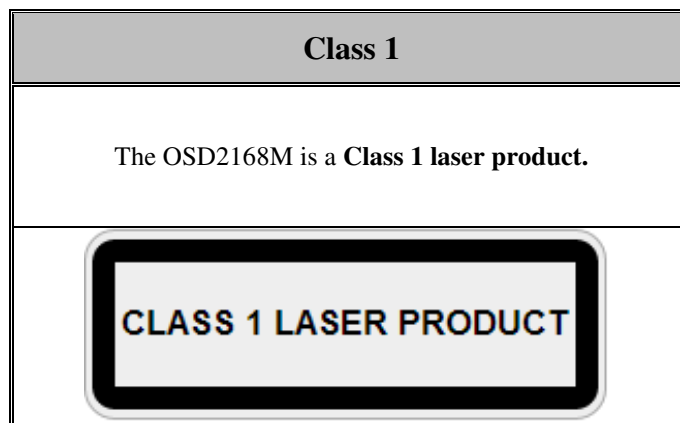

PRECAUTIONS

- ▲ All service personnel should be provided training as to the hazards of direct viewing of laser radiation and of the precautionary measures during servicing of equipment
- ▲ Areas where laser products are installed should be restricted in access to trained service personnel only and appropriate warning signs posted in the work area.
- ▲ All laser apertures should be covered by protective covers when not connected to optical fibers. Never leave outputs uncovered.
- ▲ Laser equipment should be positioned above or below eye level where possible. Apertures should be positioned away from personnel.
- ▲ Protective eyewear should be worn in the vicinity of laser equipment.

OPTICAL SYSTEMS DESIGN

2.2.2 OSD2168M DRAWINGS AND DIMENSIONS

The OSD2168M is designed to be mounted on an even surface and to be secured by means of M4 or smaller screws.

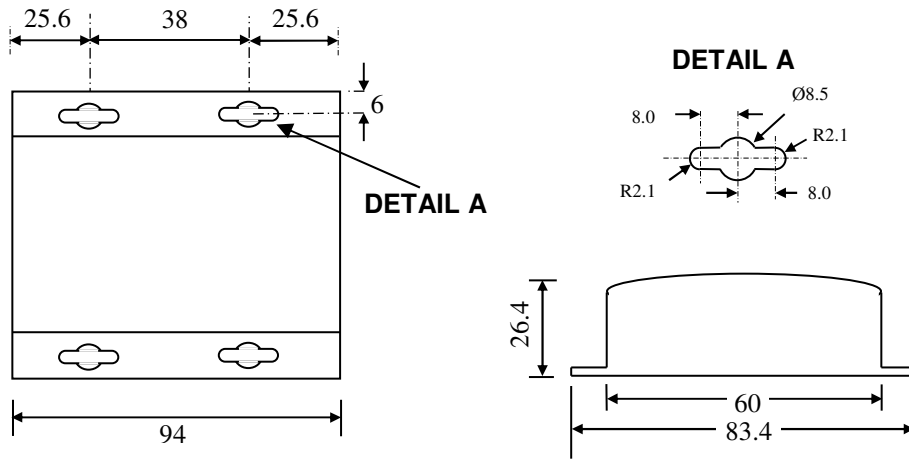

FIGURE 3: OSD2168M MOUNTING DIMENSIONS

2.2.3 POWER SUPPLY CONNECTIONS

The OSD2168M module requires isolated external DC power. The voltage range of the OSD2168M is $-50V_{DC}$ to $-56V_{DC}$. Power should be connected to the power socket located at the back of the case as indicated in Table 2.

TABLE 2: DC POWER CONNECTION

Power Connection	Specification
Internal Pin	$8V_{DC}$ to $35V_{DC}$
External	Ground – 0V

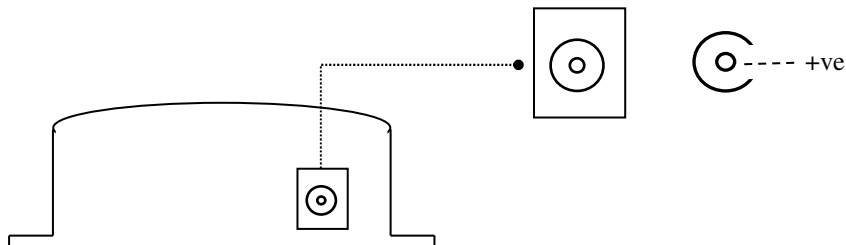

FIGURE 4: 2168M POWER SUPPLY CONNECTIONS

OPTICAL SYSTEMS DESIGN

2.2.4 FIXED RJ45 COPPER PORT PIN ASSIGNMENTS

Figure 5 shows the pin configuration for the fixed RJ45 copper port.

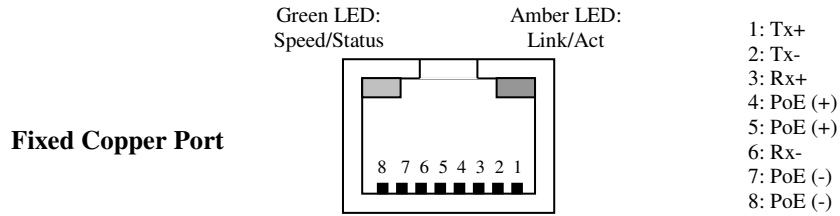

FIGURE 5: FIXED RJ45 ETHERNET CONNECTOR

2.2.5 LED INDICATORS

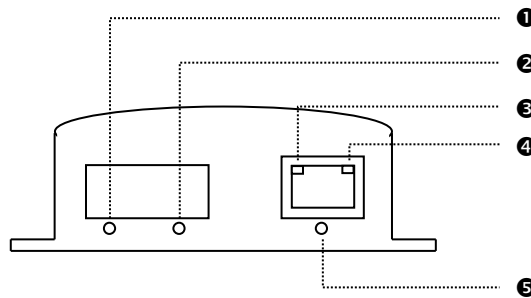

FIGURE 6: LED INDICATORS

TABLE 3: LED FUNCTION

No	Function				
		On		Off	Blinking
❶	Fiber Link/Act	Fiber Link Established	Green	No Fiber Link	Activity ⁽¹⁾
❷	Power	Power On	Green	Power Off	-
❸	Copper Speed/Status	Copper Link Green/Amber: 10/100Mbps Green: 1Gbps	Green/ Amber	No Copper Link	-
❹	Copper Link/Act	Copper Link Established	Green or Amber	No Copper Link	Activity ⁽¹⁾
❺	PoE	PD ⁽²⁾ detected	Green	No PD ⁽²⁾ detected	-

Notes: (1) Activity indicates traffic for both copper and fiber port.
 (2) PD: Powered Device

2.2.6 BASIC CONNECTIONS

Figure 7 shows basic user connections to the OSD2168M

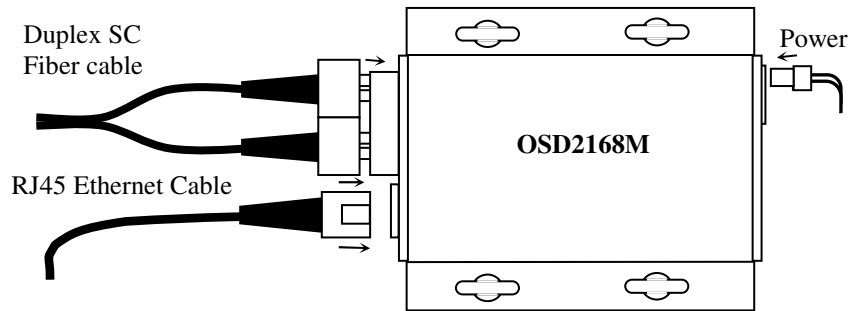

FIGURE 7: BASIC CONNECTIONS

3 MAINTENANCE

3.1 INTRODUCTION

The following section outlines the fault-finding procedure for the OSD2168M modems. Please take note of the following:

- ▲ Personnel without appropriate training should not attempt any maintenance except that outlined below.
- ▲ If further maintenance is attempted you are warned that every care should be taken to ensure that internal measurements made while the equipment is operational are taken carefully as some components within the unit are expensive and may be damaged by failure of any portion of their support circuitry.
- ▲ Some components within the unit are Electrostatic (ES) sensitive and Electrostatic Discharge (ESD) precautions should be taken when performing maintenance upon the unit.

3.2 EXTERNAL INSPECTION

Visually check for the following:

- ▲ Check that the correct power source is connected to the power socket.
- ▲ Check that the Ethernet cables are connected to the modem correctly and that the distant OSD2168M modem has been connected correctly to any external equipment.
- ▲ Inspect the optical connectors (for fiber SFP option) for any contamination and clean using isopropyl alcohol and a lint free tissue if any contamination is detected.

3.3 ROUTINE MAINTENANCE

- ▲ There is no routine maintenance required with the OSD2168M.

4 WARRANTY

Thank you for purchasing equipment designed, manufactured and serviced by Optical Systems Design (OSD). OSD warrants that at the time of shipment, its products are free from defects in material and workmanship and conforms to specifications. Our Warranty conditions are outlined below:

4.1 WARRANTY PERIOD

For warranty period, please call your local OSD distributor.

4.2 REPAIRS

Optical Systems Design reserves the right to repair or replace faulty modules/units. Please obtain a "Return Material Authorisation" (RMA) form and number before returning goods.

Goods must be returned in adequate packing material to Optical Systems Design, Warriewood or its nominated authorised representative, for all repairs.

4.2.1 WARRANTY REPAIRS

Return shipments to OSD shall be at customer's expense and freight back to the customer will be at OSD expense.

4.2.2 OUT-OF-WARRANTY REPAIRS

OSD reserves the right to repair or replace any faulty goods. Freight costs and insurance for both journeys are met by the user. All equipment repaired by OSD will have a 3-Month Warranty from the date of dispatch.

4.2.3 SITE REPAIRS

By agreement site repairs may be undertaken for which out of pocket, hotel and travel expenses will be charged.

4.2.4 EXCLUSIONS

This warranty does not apply to defects caused by unauthorized modifications, misuse, abuse or transport damage to the equipment. All modifications to OSD's standard product will need written authorization and will be charged at normal repair rates. All modifications are to be carried out by OSD Technicians. Warranty is void if unauthorized removal and/or tampering with serial number and/or repair labels is evident.

OPTICAL SYSTEMS DESIGN

Optical Systems Design Pty. Ltd.

7/1 Vuko Pl. Warriewood 2102

P.O. Box 891 Mona Vale

N.S.W. Australia 2103

Telephone: +61 2 9913 8540

Facsimile: +61 2 9913 8735

Email: sales@osd.com.au

Web Site: www.osd.com.au

OPTICAL

SYSTEMS

DESIGN

PTY LTD

A.B.N. 83 003 020 504

Printed in Australia