OPTICAL

SYSTEMS

DESIGN

OPERATOR MANUAL

OSD2251P SERIES

4-PORT REDUNDANT RING

**GIGABIT ETHERNET SWITCH WITH
PoE++ SOURCE**

OPTICAL SYSTEMS DESIGN

INDEX 1

1	TECHNICAL SUMMARY	5
1.1	BRIEF DESCRIPTION	5
1.1.1	OVERVIEW	5
1.1.2	APPLICATIONS	6
1.1.3	FEATURES AND BENEFITS	6
1.2	TECHNICAL SPECIFICATIONS	7
1.3	PORT ALLOCATION	8
2	INSTALLATION AND OPERATION	9
2.1	INTRODUCTION	9
2.2	INSTALLATION	9
2.2.1	WARNING AND PRECAUTIONS	9
2.2.2	DRAWINGS AND DIMENSIONS	10
2.2.3	LOCATION	11
2.2.4	POWER SUPPLY CONNECTIONS	11
2.2.5	ALARM CONNECTION	12
2.2.6	USB CONNECTOR	13
2.2.7	LED INDICATORS	14
2.2.8	CONTROLS	15
2.2.9	FITTING SFP CONNECTORS	16
2.3	OPERATION	17
2.3.1	CONNECTIONS	17
2.4	MINI USB PORT	19
2.5	COMMAND LINE INTERFACE	20
2.5.1	TERMINAL EMULATION SETUP	20
2.5.2	COMMAND LINE FUNCTIONS	21
2.6	WEB GUI	34
2.6.1	LOGGING ON TO THE SWITCH	35
2.6.2	GUI MENU	36
3	MAINTENANCE	44
3.1	INTRODUCTION	44
3.2	EXTERNAL INSPECTION	44
3.3	ROUTINE MAINTENANCE	44
4	WARRANTY	45
4.1	WARRANTY PERIOD	45
4.2	REPAIRS	45
4.2.1	WARRANTY REPAIRS	45
4.2.2	OUT-OF-WARRANTY REPAIRS	45
4.2.3	SITE REPAIRS	45
4.2.4	EXCLUSIONS	45
	FIGURE 1: TYPICAL RING CONFIGURATION	5
	FIGURE 2: PORT ALLOCATION	8
	FIGURE 3: MOUNTING DIMENSIONS	10
	FIGURE 4: POWER SUPPLY CONNECTIONS	11
	FIGURE 5: ALARM OUTPUTS	12
	FIGURE 6: CONTACT CLOSURE OUTPUT	12
	FIGURE 7: USB TYPE B CLI PORT	13
	FIGURE 8: CLI DRIVER DOWNLOAD	13
	FIGURE 9: LED INDICATORS	14
	FIGURE 10: SWITCH CONTROLS	15
	FIGURE 11: 8-WAY DIP SWITCH	15
	FIGURE 12: FITTING/REMOVING SFP CONNECTORS	16
	FIGURE 13: REDUNDANT RING CONFIGURATION	17
	FIGURE 14: REDUNDANT RING CONNECTION	18

OPTICAL SYSTEMS DESIGN

FIGURE 15: BUS CONNECTION	18
FIGURE 16: MINI USB CONNECTOR	19
FIGURE 17: SERIAL PORT SETTINGS.....	20
FIGURE 18: VERSION CHECK.....	22
FIGURE 19: DEFAULT SETTING.....	23
FIGURE 20: IP CONFIGURATION	24
FIGURE 21: TOPOLOGY CHECK.....	25
FIGURE 22: TOPOLOGY CHECK.....	26
FIGURE 23: NODE CHECK.....	27
FIGURE 24: LOCAL NODE CHECK.....	28
FIGURE 25: FLOAT BACKUP ENABLED 1	29
FIGURE 26: RING TOPOLOGY	29
FIGURE 27: FLOAT BACKUP ENABLED 2	30
FIGURE 28: FLOAT BACKUP ENABLED 3	30
FIGURE 29: FLOAT BACKUP DISABLED 1	31
FIGURE 30: FLOAT BACKUP DISABLED 2	32
FIGURE 31: FLOAT BACKUP DISABLED 3	32
FIGURE 32: NODE IP SET	33
FIGURE 33: NODE ALL CHECK	33
TABLE 1: TECHNICAL SPECIFICATIONS.....	7
TABLE 2: DC OR AC POWER CONNECTION.....	11
TABLE 3: ALARM CONNECTIONS.....	12
TABLE 4: LED FUNCTION	14
TABLE 5: 8-WAY DIP SWITCH SETTINGS.....	15
TABLE 6: TERMINAL COMMAND LINES	21

1 TECHNICAL SUMMARY

1.1 BRIEF DESCRIPTION

1.1.1 OVERVIEW

The OSD2251P is a 4-port industrial switch with redundant ring Gigabit Ethernet and PoE++ Source providing simple network management with real-time monitoring. It has two 10/100/1000Base-T RJ45 copper ports and two SFP ports for ring/bus configuration.

The OSD2251P incorporates redundant ring technology providing maximum reliability on critical networks. In the event of device or fiber failure the data path will automatically switch to a secondary path in less than 2ms per hop to maintain ring network integrity.

The OSD2251P has Power over Ethernet++ (PoE++) function and operates as a Power Source Equipment (PSE). The OSD2251P PoE++ can provide up to 60W to each RJ45 port to Powered Devices (PD). The unit will operate on either singlemode or multimode fiber. Operation over a network of hundreds of kilometers is possible by use of the appropriate optical devices. It normally requires two fibers but is optionally available for one fiber operation per port.

A major benefit of the OSD2251P is its reliable and consistent performance over the -20°C to +75°C temperature range that allows it to be used in uncontrolled environments such as roadside cabinets, mine sites and factories.

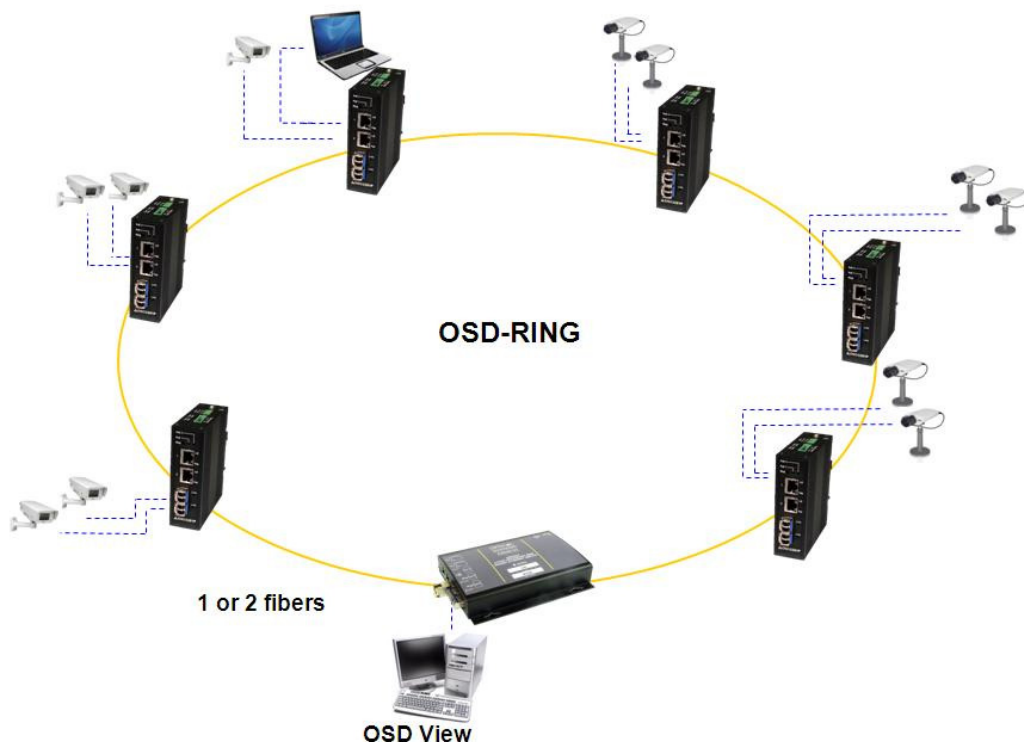

FIGURE 1: TYPICAL RING CONFIGURATION

OPTICAL SYSTEMS DESIGN

1.1.2 APPLICATIONS

- ▲ Any network utilising a mix of copper and fiber
- ▲ Industrial IP communications
- ▲ Self-healing Gigabit Ethernet backbone networks
- ▲ Networks using Power over Ethernet devices such as cameras, intercoms, access control, telephones, etc.

1.1.3 FEATURES AND BENEFITS

- ▲ Complies with IEEE802.3i/802.3u/802.3ab 10/100/1000Base-T, IEEE802.3u, 100Base-Fx, IEEE802.3z 1000Base-Lx/Sx standards
- ▲ Has a total of four ports: two fixed copper ports for 10/100/1000Base-T and two SFP ports for the fiber ring or non-ring (100Base-Fx or 1000Base-X)
- ▲ A network diameter of hundreds of kilometers is practical
- ▲ Ring reconfiguration in the case of cable or switch failures takes less than two milliseconds per hop
- ▲ MDI/MDIX Crossover: no need for crossover cables
- ▲ Can be used with either singlemode or multimode fiber over a variety of link budgets
- ▲ Auto-Negotiation for half or full duplex operation
- ▲ Supports IEEE802.3af/at Alternative A and B cable wiring
- ▲ Provides up to 60W to each RJ45 port
- ▲ Complies with the IEEE802.3af/at standard including compliant powered device (PD) signature detection and classification
- ▲ Powered by either one or two non-critical 46 to 57V_{DC} supplies
- ▲ Operates over the temperature range of -20°C to +75°C
- ▲ Compatible with the OSD2244, OSD2254 and OSD2258 Gigabit Ethernet Switches.
- ▲ DIN rail Mounting
- ▲ Available for operation in Ring or point-to-point configuration
- ▲ OSDview Lite Network Management System Standard
- ▲ OSDWeb Web browser GUI
- ▲ SFP modules sold separately
- ▲ Supports 10KB jumbo frames

OPTICAL SYSTEMS DESIGN

1.2 TECHNICAL SPECIFICATIONS

TABLE 1: TECHNICAL SPECIFICATIONS

SPECIFICATION	PERFORMANCE
Electrical Data Interface	IEEE802.3i/802.3u/802.3ab/802.3af/802.3at, 10/100/1000Base-T Ethernet
Electrical Data Rate	10, 100, 1000Mbps with energy detect, auto negotiate, auto MDIX
Jumbo Frame Support	10KB
Optical Data Interface	IEEE802.3z 1000Base-Lx/Sx or IEEE802.3u 100Base-Fx
Optical Data Rate	100Mbps or 1000Mbps user selectable
Operating Mode	Ring or non-ring user selectable Half or full duplex for 10/100 Full duplex for 1000 Flow control
Electrical Data Connectors	RJ45
Alarms	Ring to Bus High Temperature
Alarm Interface	Optoisolated MOSFET rated at 100mA @ 46V maximum
PoE	IEEE802.3af, IEEE802.3at and PoE++
Operating Mode	Alternative A & B (Pins 1/2, 3/6, 4/5 and 7/8)
Optical Port Connectors	SFP
SFP Options	Short haul, long haul, single fiber operation, etc. Please consult OSD DATASHEET #100210000x or contact OSD
Indicators	2x Copper Link 2x Copper Activity 2x PoE Operation on RJ45s 2x SFP Speed/Activity/Link on SFPs 1x Power/temperature Alarm 1x Initialise/Ring/Bus
Dimensions (mm)	43W x 91D x 110H
Weight	0.48kg
Power Requirements	46 to 57V _{DC} @ 1.5A maximum (attached powered device dependant) >52V _{DC} recommended for PoE+ or ≥55V _{DC} for 60W PoE
Power Connector	4 way 5.08mm terminal block
Alarm Connector	4 way 3.5mm terminal block
Operating Temperature	-20°C to +75°C
Relative Humidity	0 to 95% non-condensing

1022251P08

OPTICAL SYSTEMS DESIGN

1.3 PORT ALLOCATION

Front Panel: There are two fixed copper ports for 10/100/1000Base-T and two SFP ports.

Top Panel: The top panel consists of a 4-way 5.08mm terminal block power connector and a 4-way 3.5mm terminal block alarm connector.

Bottom Panel: 8-Way DIP switch, Mini USB connector and a Type-B USB connector.

Each section will be described further throughout this manual.

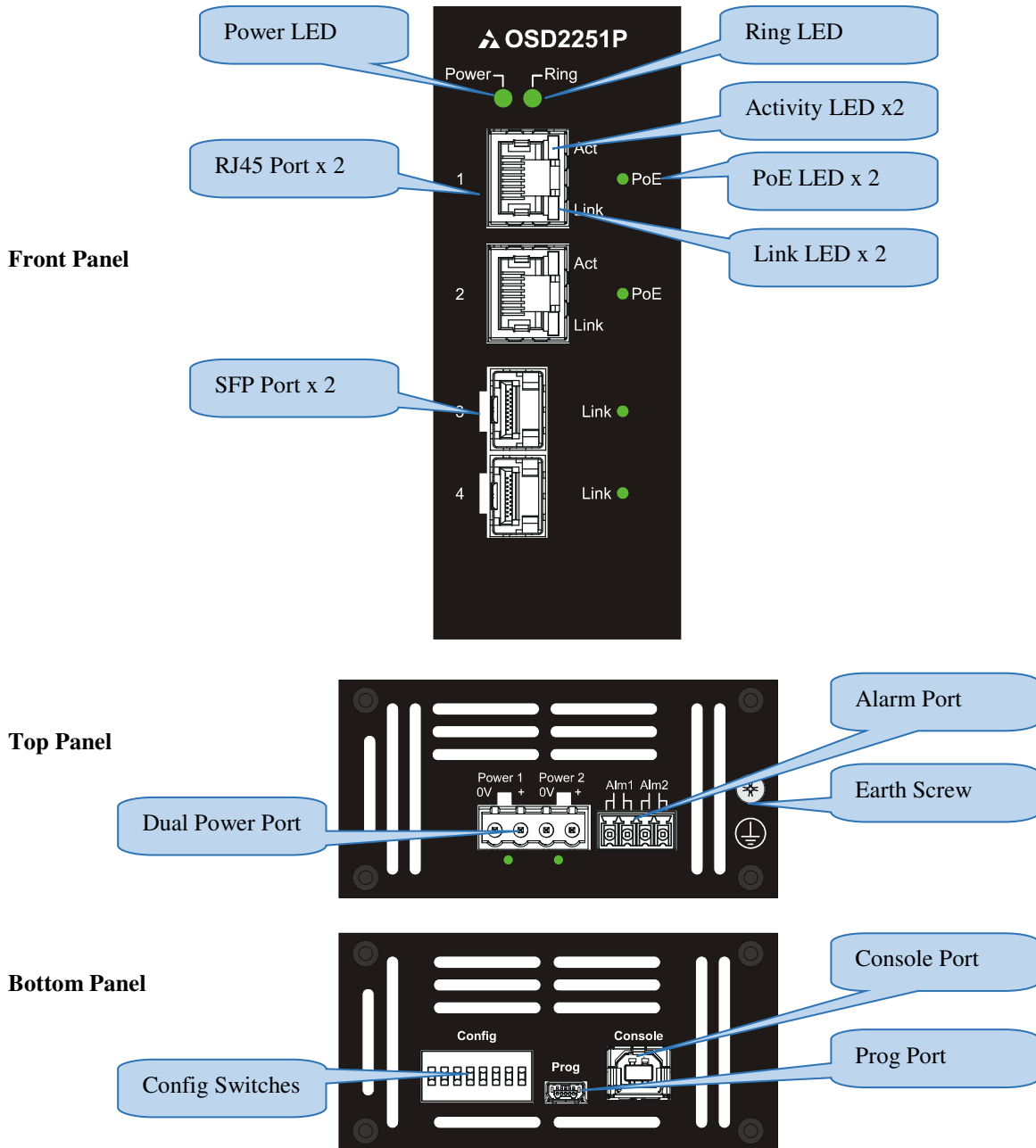

FIGURE 2: PORT ALLOCATION

2 INSTALLATION AND OPERATION

2.1 INTRODUCTION

This section outlines the methods required to install and operate the OSD2251P successfully. It should be studied carefully if damage to the equipment or poor results are to be avoided.

This equipment has been fully tested prior to dispatch and is ready for immediate operation. However it is advisable to check for external transportation damage before operation. If damage is evident, return the unit with the packaging to your supplier immediately.

2.2 INSTALLATION

2.2.1 WARNING AND PRECAUTIONS

▲ ELECTROMAGNETIC COMPATIBILITY

WARNING: This is a Class A product. In a domestic environment this product may cause radio interference in which case the user may be required to take adequate measures.

▲ OPTICAL OUTPUT OPERATION

WARNING: Laser Safety: Class 1 Laser Product per IEC/EN 60825-1:2014 standard.

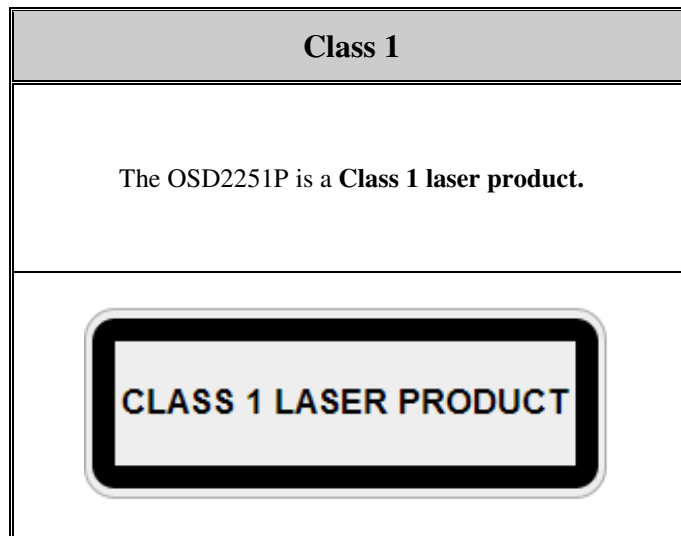

PRECAUTIONS

- ▲ All service personnel should be provided training as to the hazards of direct viewing of laser radiation and of the precautionary measures during servicing of equipment
- ▲ Areas where laser products are installed should be restricted in access to trained service personnel only and appropriate warning signs posted in the work area.
- ▲ All laser apertures should be covered by protective covers when not connected to optical fibers. Never leave outputs uncovered.
- ▲ Laser equipment should be positioned above or below eye level where possible. Apertures should be positioned away from personnel.
- ▲ Protective eyewear should be worn in the vicinity of laser equipment.

OPTICAL SYSTEMS DESIGN

2.2.2 DRAWINGS AND DIMENSIONS

The OSD2251P is designed to be surface mounted or wall mounted onto a DIN-Rail (35mm top hat) fixture. The unit dimensions (excluding connectors, SFPs, etc) is shown in Figure 3 below;



FIGURE 3: MOUNTING DIMENSIONS

OPTICAL SYSTEMS DESIGN

2.2.3 LOCATION

The OSD2251P should be placed where it will not be subjected to extreme temperatures, humidity, or electromagnetic interference. Specifically, the site selected should meet the following requirements:

- The ambient temperature should be between -20°C to 75°C.
- The relative humidity should be less than 95 percent, non-condensing.
- Surrounding electrical devices should not exceed the electromagnetic field (RFC) standards.
- Make sure that the switch receives adequate ventilation. Do not block the ventilation holes on any side of the switch.

Note: Without proper cooling and control (lowering) of ambient temperature, the components within the OSD2251P can be subject to increased heat shortening the longevity and reliability. It is thus good engineering practice to ensure the unit is installed in a well ventilated area.

2.2.4 POWER SUPPLY CONNECTIONS

The OSD2251P requires external power to the Redundant DC Terminal Block Power Connector located at the top of the unit. Always ensure that the power is off before any installation.

Redundant DC Terminal Block Power Inputs

There are two pairs of power inputs for use with redundant power sources. Only one power input is required to be connected to run the switch.

Step 1: Connect the DC power to the appropriate power source, connect the plug-able terminal block on the OSD2251P switch and then turn power on.

Step 2: Disconnect the power if you want to shut down the switch.

TABLE 2: DC OR AC POWER CONNECTION

External Power Pin	Specification
Power 1: +	46V _{DC} to 57V _{DC} @ 1.5A*
Power 1: 0V	Ground – 0V
Power 2: +	46V _{DC} to 57V _{DC} @ 1.5A*
Power 2: 0V	Ground – 0V
	Earth Ground Connection

*≥52V_{DC} recommended for PoE+ or ≥ 55V_{DC} for 60W PoE

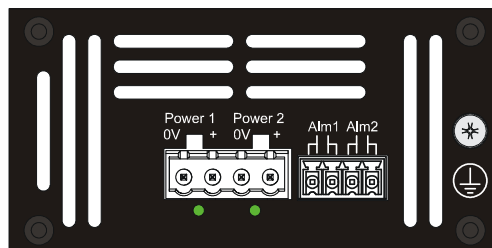

FIGURE 4: POWER SUPPLY CONNECTIONS

OPTICAL SYSTEMS DESIGN

2.2.5 ALARM CONNECTION

The OSD2251P has two monitoring alarm outputs: 1) Ring to Bus Alarm and 2) Temperature Alarm. The alarm connections and conditions for alarm outputs are as set out in Table 3. There are four pins on the 3.5mm terminal block used alarm output. Maximum ratings the OSD2251P relay can drive is 100mA @ 46V_(max). Note: Alarm output has no polarity.

TABLE 3: ALARM CONNECTIONS

Alarm Output	Alarm1 Ring /Bus Status	Alarm CH2 Temperature
Open	Ring	Less than 90°C
Closed	Bus*	Higher than 90°C

*Note: Bus alarm is only triggered *after* a ring connection is established.

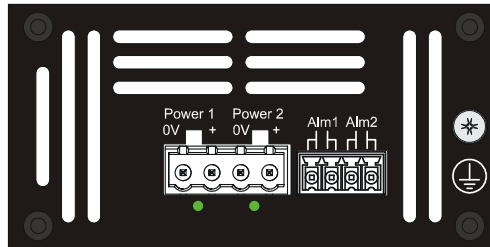

FIGURE 5: ALARM OUTPUTS

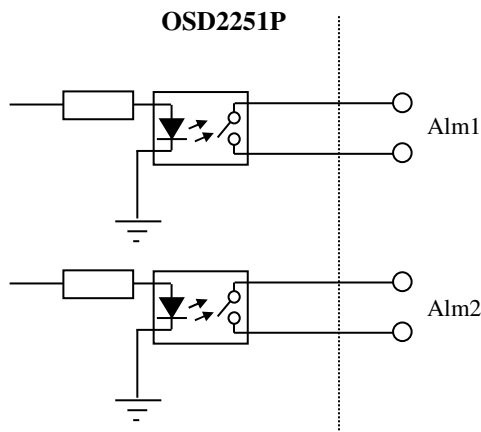

FIGURE 6: CONTACT CLOSURE OUTPUT

OPTICAL SYSTEMS DESIGN

2.2.6 USB CONNECTOR

The OSD2251P has a USB – Type B connector located on the bottom of the unit that is used for Command Line Interface (CLI) from the PC to the OSD2251P via the PC’s USB connector. See section 2.5 for further CLI information.

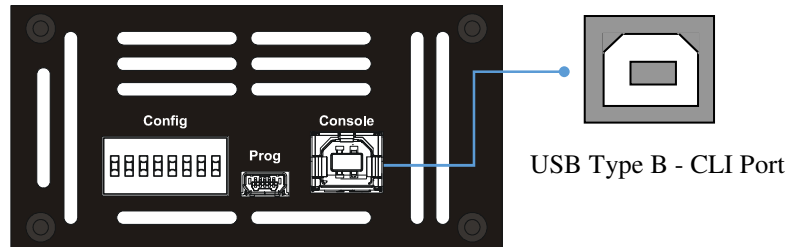

FIGURE 7: USB TYPE B CLI PORT

To operate and control the OSD2251P using the CLI, a proprietary driver will be required to be installed onto the PC being used. The driver can be found and downloaded via the following site: www.silabs.com and searching for the CP210x driver. Download the relevant driver for your operating system, install and follow the installation instructions from your PC.

Download for Windows 10 Universal (v10.1.7)

Platform	Software	Release Notes
Windows 10 Universal	Download VCP (2.3 MB)	Download VCP Revision History

Download for Windows 7/8/8.1 (v6.7.6)

Platform	Software	Release Notes
Windows 7/8/8.1	Download VCP (5.3 MB) (Default)	Download VCP Revision History
Windows 7/8/8.1	Download VCP with Serial Enumeration (5.3 MB) Learn More >	Download VCP Revision History

Download for Windows XP/Server 2003/Vista/7/8/8.1 (v6.7)

Platform	Software	Release Notes
Windows XP/Server 2003/Vista/7/8/8.1	Download VCP (4.6 MB)	Download VCP Revision History

Download for Windows 2K (v6.3a)

Platform	Software	Release Notes
Windows 2K	Download VCP (4.79 MB)	Download Win2K VCP Revision History

Download for WinCE

Platform	Software	Release Notes
WinCE 6.0 (2.1)	Download VCP (276 KB)	Download WinCE 6.0 Revision History
WinCE 5.0 (2.1)	Download VCP (271 KB)	Download WinCE 5.0 Revision History

Download for Macintosh OSX (v5.1.0)

Platform	Software	Release Notes
Mac OSX	Download VCP (852 KB)	Download Mac VCP Revision History

Download for Linux

Platform	Software	Release Notes
Linux 3.x.x and 4.x.x	Download VCP (10.0 KB)	Download Linux 3.x.x and 4.x.x VCP Revision History
Linux 2.6.x	Download VCP (10.2 KB)	Download Linux 2.6.x VCP Revision History

Note: The Linux 3.x.x and 4.x.x version of the driver is maintained in the current Linux 3.x.x and 4.x.x tree at www.linux.com.

Download for Android

Platform	Application Note
Android 4.2	AN609: Integrating the CP210x Virtual COM Port Driver into the Android Platform

FIGURE 8: CLI DRIVER DOWNLOAD

OPTICAL SYSTEMS DESIGN

2.2.7 LED INDICATORS

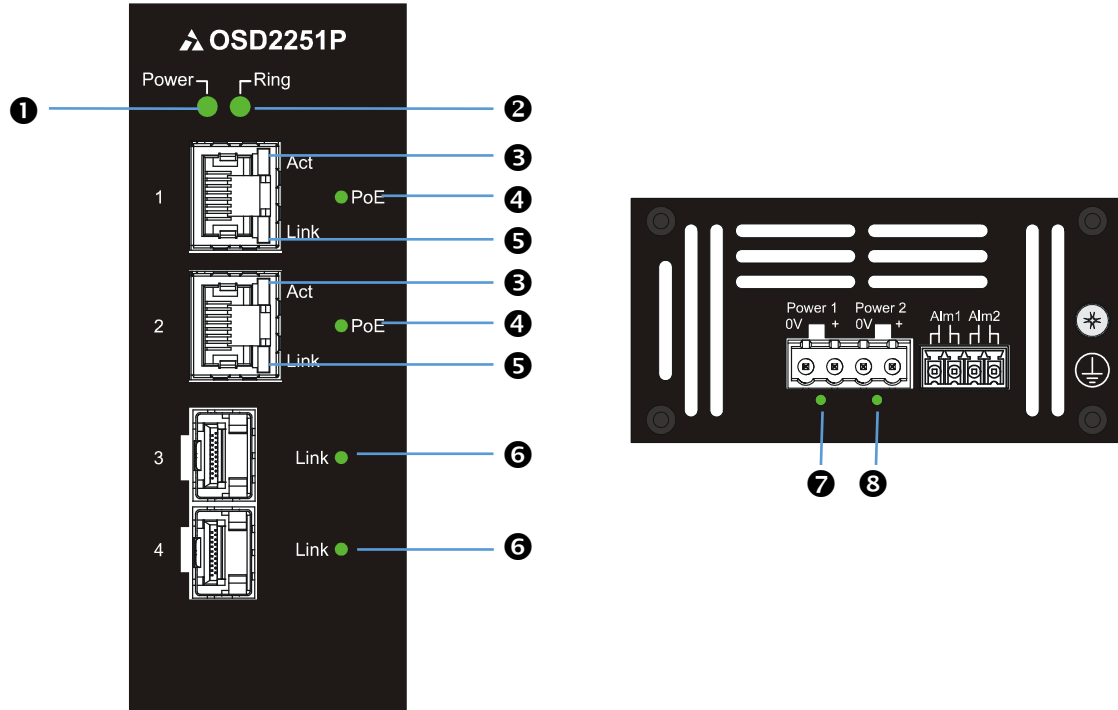

FIGURE 9: LED INDICATORS

TABLE 4: LED FUNCTION

No	Function			LED Colour Function		
	On	Blink	Off	Green	Gr/Am	Amber
①	Power	-	No Power	On	-	-
②	Ring/Bus	Initial	Unmanaged Mode/ Programming	Ring	Initializing	Bus
③	-	Activity	No Activity	1Gbps/100Mbps	-	-
④	Load Detect	-	No Load	LD	-	-
⑤	Link	-	No Link	-	-	On
⑥	Link	Activity	No Link	1Gbps	-	100Mbps
⑦	Power 1	-	No Power	On	-	-
⑧	Power 2	-	No Power	On	-	-

OPTICAL SYSTEMS DESIGN

2.2.8 CONTROLS

The OSD2251P has an 8-way DIP switch to control a number of functions. Table 5 outlines the function of each switch.

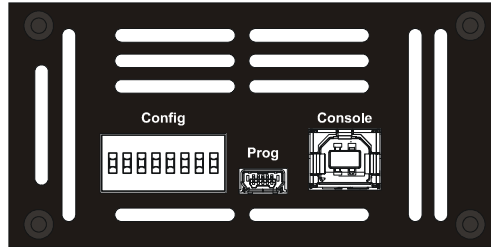

FIGURE 10: SWITCH CONTROLS

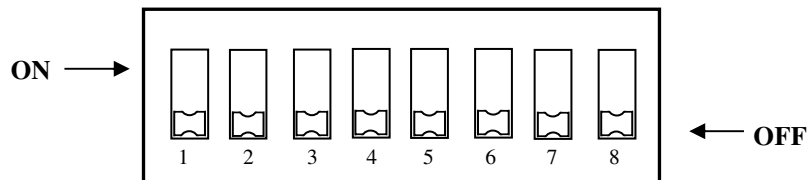

FIGURE 11: 8-WAY DIP SWITCH

TABLE 5: 8-WAY DIP SWITCH SETTINGS

SWITCH NUMBER	DESCRIPTION	FUNCTION	SWITCH POSITION
1	Port 4 Fiber Speed	100Mbps	ON
		1Gbps	OFF*
2	Port 3 Fiber Speed	100Mbps	ON
		1Gbps	OFF*
3	Ring/Non Ring Mode	Non Ring Mode	ON
		Ring Mode	OFF*
4	Reserved	-	OFF*
5	Not Used	-	OFF*
6	Not Used	-	OFF*
7	Not Used	-	OFF*
8	Not Used	-	OFF*

* Default settings.

Note: The unit requires a power cycle (Off/On) for any switch position change to take effect.

OPTICAL SYSTEMS DESIGN

2.2.9 FITTING SFP CONNECTORS

Care should be taken when inserting/removing the SFP connectors from SFP port 3 and 4 as SFP modules are Electrostatic (ES) sensitive and Electrostatic Discharge (ESD) precautions should be taken when installing. Ensure that the SFP is fully engaged and latched into position.

Inserting SFP – Ensure that the SFP lever is in the locked position and insert into appropriate SFP port. Gently push the SFP until it locks into place. Remove plastic/rubber dust cap and fit fiber cable or RJ45 plug.

Removing SFP – Remove fiber connector or RJ45 plug. Pull the SFP lever down to unlock SFP from housing. Using the lever, gently pull the SFP out.

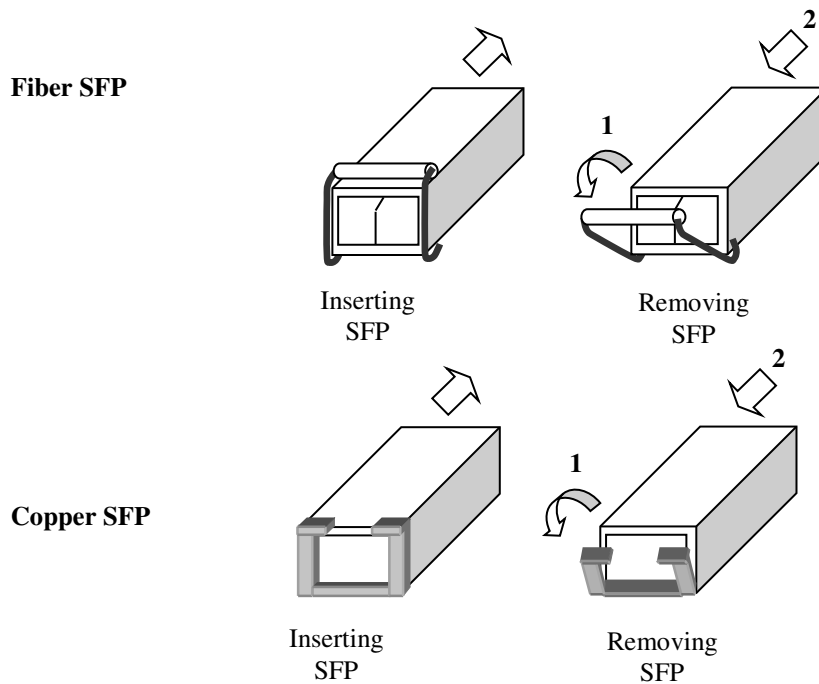

FIGURE 12: FITTING/REMOVING SFP CONNECTORS

OPTICAL SYSTEMS DESIGN

2.3 OPERATION

When using the OSD2251P for the first time, check that the unit is in good condition with no visible damage.

Upon power up check that the indicators illuminate accordingly on power up (see Table 4).

2.3.1 CONNECTIONS

For RJ45 connection use Category 5 (CAT5) or higher. Length should be no more than 100 meters.

For singlemode fiber connections, fiber used must be 9/125 μ m singlemode fiber.

For multimode fiber connections, fiber used must be 50/125 μ m or 62/125 μ m multimode fiber.

Plug in the appropriate connectors for system configuration;

- RJ45 cable to fixed copper ports (port 1 and 2) and copper SFP modules
- LC or SC fiber cable to fiber SFP modules.

Redundant Ring Operation

The OSD2251P connected in a redundant ring topology providing maximum reliability on critical networks. In the event of device or fiber failure the data path will automatically switch to a secondary path in less than 2ms per node to maintain ring network integrity.



FIGURE 13: REDUNDANT RING CONFIGURATION

OPTICAL SYSTEMS DESIGN

To connect the OSD2251P in a redundant ring configuration ports 3 and 4 must be used together with fiber SFPs. The non-ring ports (ports 1 & 2) should be used to connect to your Ethernet devices (eg. Cameras, PLCs, computers, etc.)

Figure 14 shows the connection method. Typically the SFP used would be a fiber 1G (1000Mbps) SFP with duplex LC connectors. 100Mbps operation is also available for MMOF setups. The dashed line indicates the closed loop, but more OSD2251P units can be connected to the ring as required using this topology. Ensure that the switch settings for port 3 and 4 are set to the appropriate SFP speed used – see Table 5.

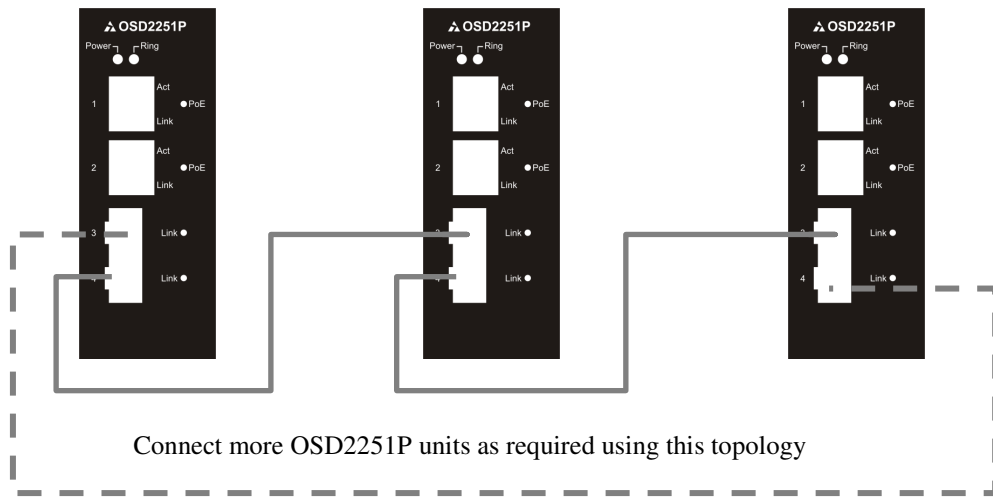

FIGURE 14: REDUNDANT RING CONNECTION

Bus Operation

To connect the OSD2251P in a bus configuration ports 3 and 4 must be used together with fiber SFPs. The remaining ports (ports 1 & 2) should be used to connect to your Ethernet devices (eg. Cameras, PLCs, computers, etc.)

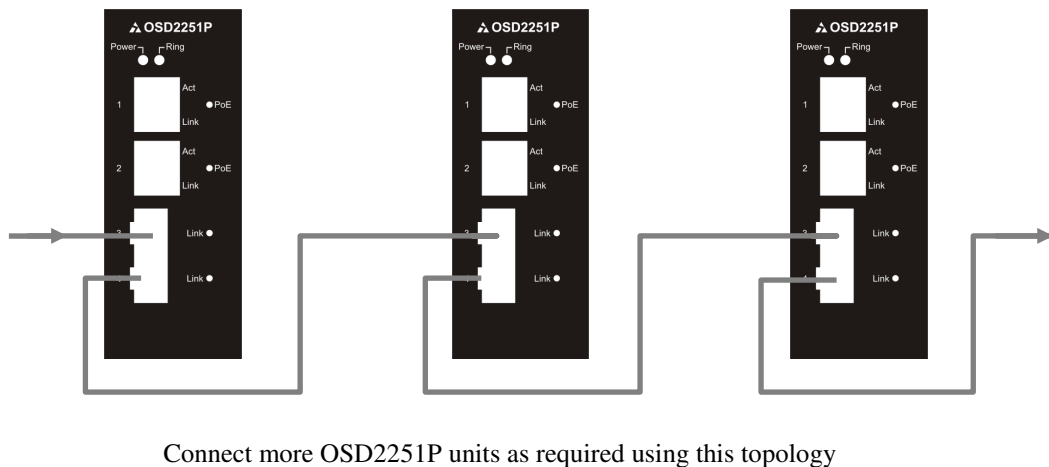

FIGURE 15: BUS CONNECTION

2.4 MINI USB PORT

The Mini USB Port is used for uploading firmware updates. All OSD2251P units will be shipped with the latest firmware already installed. This port has no function for end user.

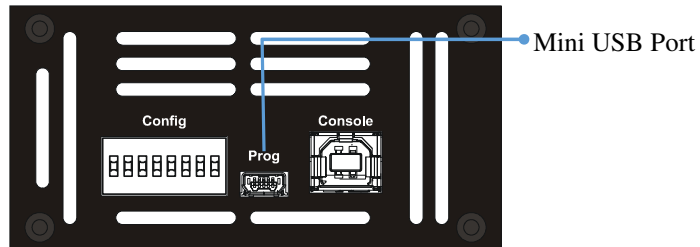

FIGURE 16: MINI USB CONNECTOR

2.5 COMMAND LINE INTERFACE

The Command Line Interface (CLI) is a useful tool for checking link status and debugging link connections. To enable the use of CLI the OSD2251P must be connected to a PC with a serial port and an appropriate cable as specified in section 2.2.6. Using a terminal emulation program such as Hyperterminal, a number of command lines specific to the OSD2251P can be implemented to check link/node status, ring/bus topology and enable/disable float backup.

2.5.1 TERMINAL EMULATION SETUP

Using a terminal emulation program such as hyperterminal the following parameters should be set up for correct command line operation. Select the appropriate “COM port” set up for the serial port.

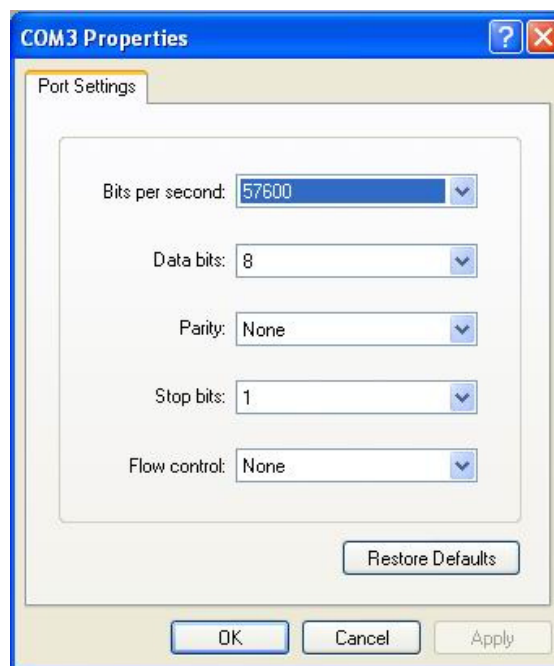

FIGURE 17: SERIAL PORT SETTINGS

OPTICAL SYSTEMS DESIGN

2.5.2 COMMAND LINE FUNCTIONS

There are a number of command line functions that enables the user to obtain running information of a single OSD2251P unit or the complete topology of the ring/bus network. This section explains the command lines and its functions.

When the terminal emulation program is operating, connect the USB cable to any one of the OSD2251P units on the ring/bus network – or alternatively, the OSD2251P unit which the user wishes to interrogate. Note: A message will be displayed on the terminal emulation program when the unit is powered after USB connection. This message will not open when the unit is switched on while plugging in the USB cable, however the command lines are functional.

The following table outlines the user available command line commands and their functions

TABLE 6: TERMINAL COMMAND LINES

TERMINAL COMMAND LINE	SPECIFICATION	FUNCTION	FIGURE
?	Help	Lists all CLI commands including input format information	-
vc	Version Check	Displays the current software version and revision installed on the unit	Figure 18
ds	Default Setting	Reset configuration to default	Figure 19
ipconfig	IP Configuration	Configure the IP address	Figure 20
tc	Topology Check	Displays the topology status of the established ring/bus	Figure 21
nc	Node Check	Gets running status of the node for given MAC address	Figure 23
lnc	Local Node Check	Gets running status of the local node	Figure 24
fbe	Float Backup Enable	Enable float backup function for all nodes in a Ring/Bus	Figure 25
fbd	Float Backup Disable	Disable float backup function for all nodes in a ring/bus	Figure 29
node_ip_set	Node IP Set	Setup IP of the node with given MAC address	Figure 32
node_all_set	Node All Set	Setup IP for all nodes on a ring/bus	Figure 33

OPTICAL SYSTEMS DESIGN

VERSION CHECK - <vc>

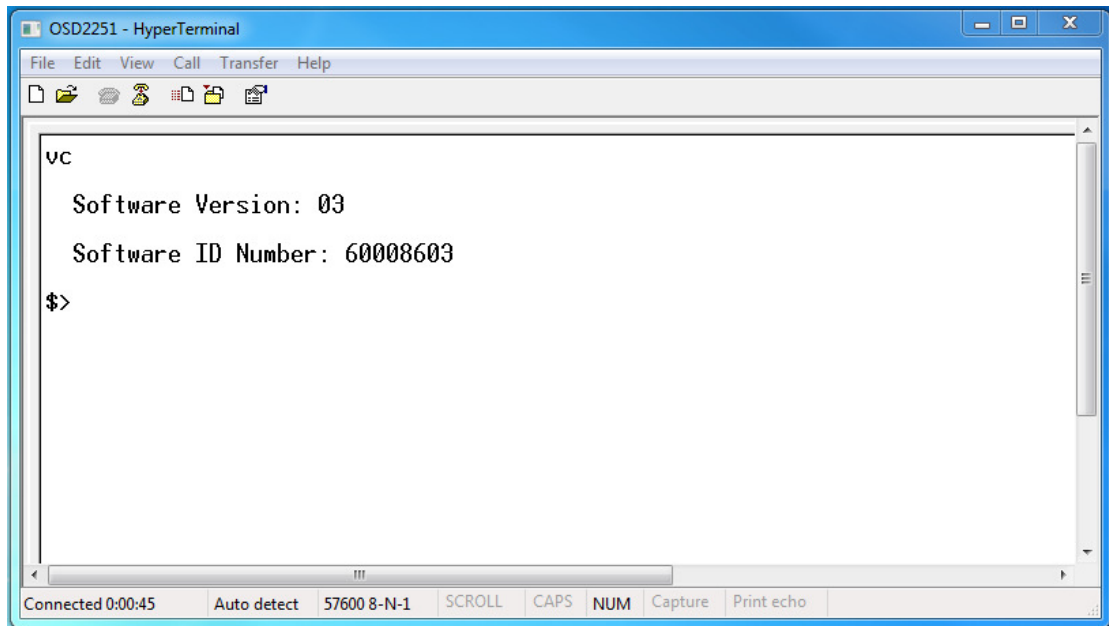

FIGURE 18: VERSION CHECK

Displays the Software Version Number and Software ID Number installed on the OSD2251P

OPTICAL SYSTEMS DESIGN

DEFAULT SETTING - <ds>

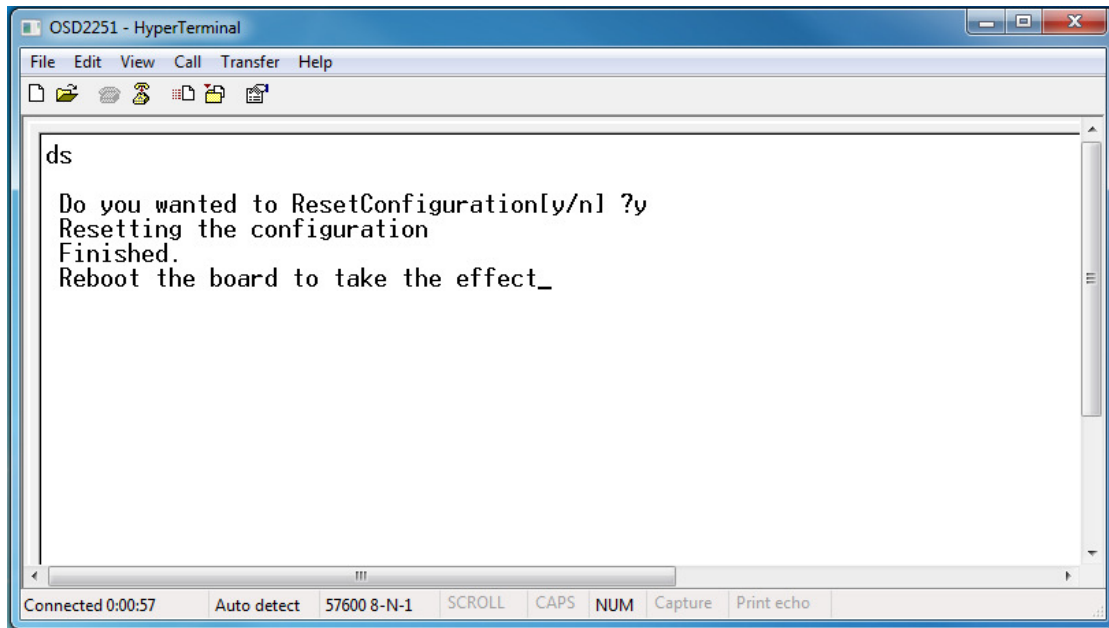

FIGURE 19: DEFAULT SETTING

Resets the OSD2251P to its default factory setting. A prompt question will appear “Do you want to Reset Configuration [y/n]?”

- n** – Exits the default configuration setting and returns to the home prompt.
- y** – Resets to default configuration sequence. The units will require a reboot for changes to take effect.

OPTICAL SYSTEMS DESIGN

IP CONFIGURATION - <ipconfig>

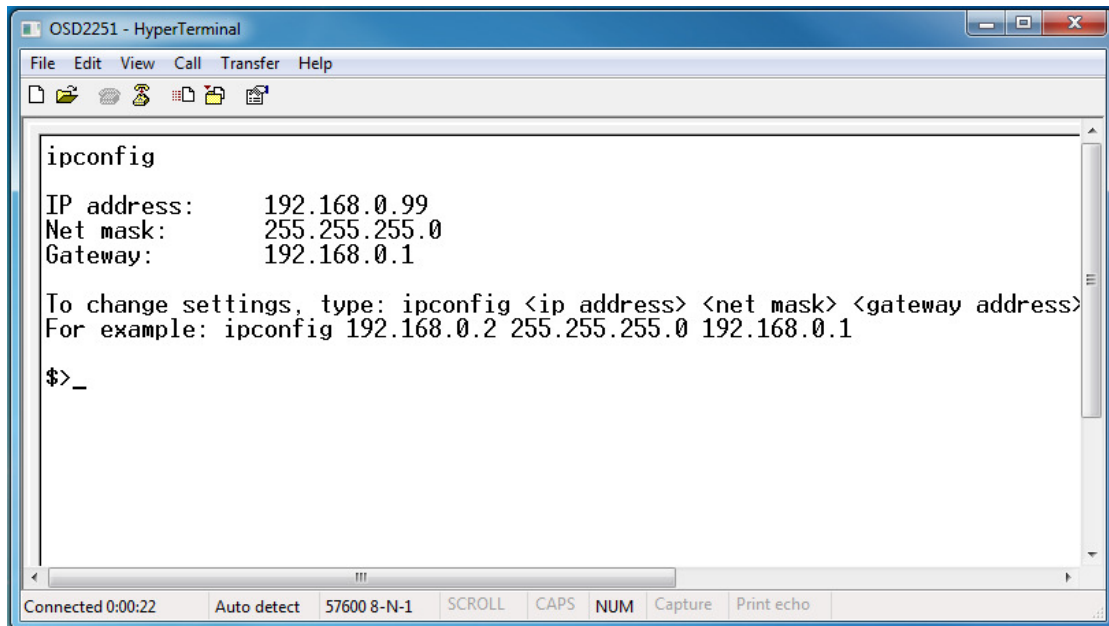

```
OSD2251 - HyperTerminal
File Edit View Call Transfer Help
ipconfig
IP address:      192.168.0.99
Net mask:       255.255.255.0
Gateway:        192.168.0.1

To change settings, type: ipconfig <ip address> <net mask> <gateway address>
For example: ipconfig 192.168.0.2 255.255.255.0 192.168.0.1

$>_
Connected 0:00:22  Auto detect  57600 8-N-1  SCROLL  CAPS  NUM  Capture  Print echo
```

FIGURE 20: IP CONFIGURATION

Displays the current IP address, Net mask and Gateway settings.

To make changes to the IP address, Net mask and Gateway, at the prompt enter the new details in the following format;

ipconfig <ip address> <netmask> <gateway address>

OPTICAL SYSTEMS DESIGN

TOPOLOGY CHECK - <tc>

```
OSD2251 - HyperTerminal
File Edit View Call Transfer Help
tc
-----
No.  MAC_ADDRESS      TOPOLOGY  NODE_ROLE  RING_P0    RING_P1
-----
1    00:26:dc:00:1e:28  Init      Slave      U_port     U_port <-local
M_port <--> Master port,    S_port <--> Slave port
B_port <--> Backup port,  U_port <--> Unconnected port
The master communicates with the local node via '*' marked port.
--- The end ---
Connected 0:00:28  Auto detect  57600 8-N-1  SCROLL  CAPS  NUM  Capture  Print echo
```

FIGURE 21: TOPOLOGY CHECK

In this case, only one OSD2251P is connected to the USB cable. The display indicates the following;

No: 1 – Number of units connected on the ring/bus (in this case only one unit)

MAC_ADDRESS: 00:26:dc:00:1e:28 – Displays all the MAC addresses of the units connected on the ring/bus

TOPOLOGY: Init – Displaying type of connection (in this case “Init” as there is only one unit)

NODE_ROLE: Slave – Displays whether the unit is either the Master or Slave on the ring/bus (in this case displaying slave). The Master unit is determined by the unit with the lowest MAC address

RING_P0: U_port. Indicates the function of port 3 and its relation to the ring/bus. There are four possibilities;

1. M_port – Master Port (port facing the master)
2. S_port – Slave Port (port back to the master)
3. B_Port – Backup Port
4. U_Port – Unconnected Port

RING_P1: U_port. Indicates the function of port 4 and its relation to the ring/bus. There are four possibilities;

1. M_port – Master Port
2. S_port – Slave Port
3. B_Port – Backup Port
4. U_Port – Unconnected Port

<-local: This points to the unit that the USB cable is plugged into on the ring/bus.

OPTICAL SYSTEMS DESIGN

In the example below there are four OSD2251P connected in a ring configuration.

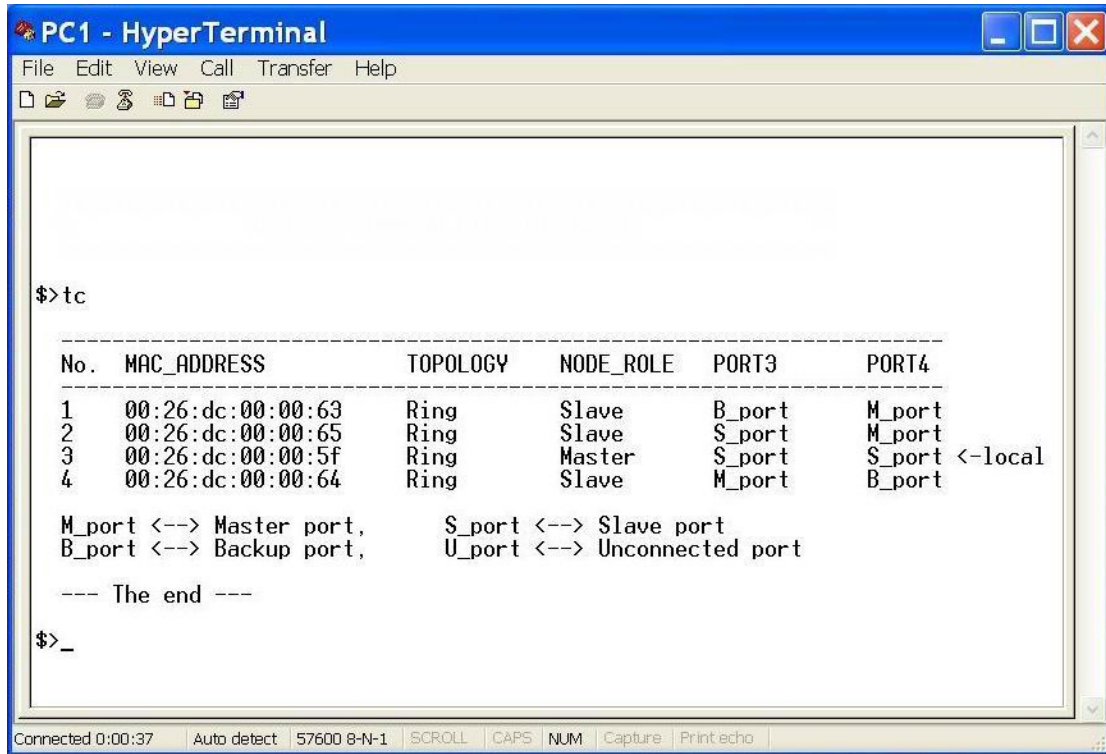

FIGURE 22: TOPOLOGY CHECK

No: 4 – Four units connected

MAC_ADDRESS:– Displaying all the MAC addresses of the units connected on the ring/bus

TOPOLOGY: Ring – Displaying type of connection.

NODE_ROLE: MASTER – Displays if the unit is either the Master or Slave on the ring/bus. Master is determined by the lowest MAC address

PORT3: U_port. Indicates the function of port 3 and its relation to the ring/bus. There are four possibilities;

1. M_port – Master Port
2. S_port – Slave Port
3. B_Port – Backup Port
4. U_Port – Unconnected Port

PORT4: U_port. Indicates the function of port 4 and its relation to the ring/bus. There are four possibilities;

1. M_port – Master Port
2. S_port – Slave Port
3. B_Port – Backup Port
4. U_Port – Unconnected Port

<-local: This points to the unit that the USB cable is plugged into on the ring/bus.

OPTICAL SYSTEMS DESIGN

NODE CHECK - <nc>

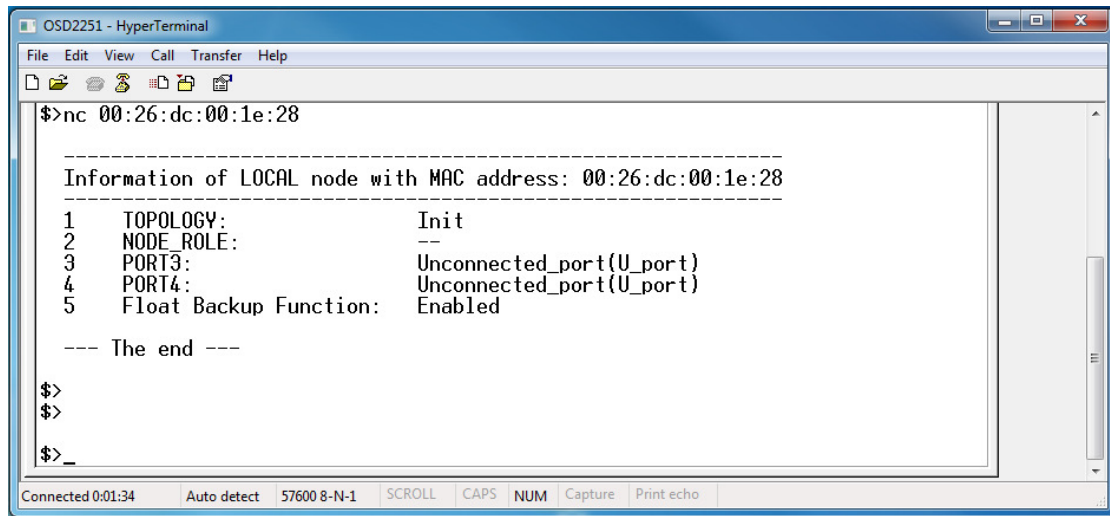

```
OSD2251 - HyperTerminal
File Edit View Call Transfer Help
$>nc 00:26:dc:00:1e:28
-----
Information of LOCAL node with MAC address: 00:26:dc:00:1e:28
-----
1  TOPOLOGY:          Init
2  NODE_ROLE:         --
3  PORT3:             Unconnected_port(U_port)
4  PORT4:             Unconnected_port(U_port)
5  Float Backup Function: Enabled
--- The end ---
$>
$>
$>_
Connected 0:01:34  Auto detect  57600 8-N-1  SCROLL  CAPS  NUM  Capture  Print echo
```

FIGURE 23: NODE CHECK

Node check obtains the running status of the node for the specific MAC address requested within the Ring/Bus.

Correct entry format is as follows (MAC address specified below is an example);

nc 00:26:dc:00:1e:28

OPTICAL SYSTEMS DESIGN

LOCAL NODE CHECK - <Inc>

```
OSD2251 - HyperTerminal
File Edit View Call Transfer Help
Inc
-----
Information of LOCAL node with MAC address: 00:26:dc:00:1e:28
-----
1 TOPOLOGY:          Init
2 NODE_ROLE:         --
3 PORT3:             Unconnected_port(U_port)
4 PORT4:             Unconnected_port(U_port)
5 Float Backup Function: Enabled
--- The end ---
$>_
Connected 0:00:21  Auto detect  57600 8-N-1  SCROLL  CAPS  NUM  Capture  Print echo
```

FIGURE 24: LOCAL NODE CHECK

This command line displays the running status of the local node that the USB cable is plugged into. The information provided is the MAC address, Topology, Node Role, Port Role and Float Backup status.

OPTICAL SYSTEMS DESIGN

FLOAT BACKUP ENABLE <fbe>

```

fbc
-----
No.  MAC_ADDRESS          FLOAT_BACKUP  SETTING_RESULT
-----
1    00:26:dc:00:00:63      Enable       OK
2    00:26:dc:00:00:65      Enable       OK      <-local
3    00:26:dc:00:00:5f      Enable       OK
4    00:26:dc:00:00:64      Enable       OK

--- The end ---
$>
  
```

FIGURE 25: FLOAT BACKUP ENABLED 1

No: 4 – Lists number of units connected (in this case 1,2,3,4)

MAC_ADDRESS:– Displaying all the MAC addresses of the units connected on the ring/bus

FLOAT_BACKUP: Enable – Displays all the units connected to the ring/bus having Float Backup enabled.

SETTING_RESULT: OK – Displays the Float Backup enable has been successfully implemented.

<-local: This points to the unit that the USB cable is plugged into on the ring/bus.

The link furthest from the Master unit in a ring configuration is automatically selected as the backup branch. In the case of even units on a ring the fiber link on port 3 will always be the backup branch – indicated by a dashed line on a ring topology.

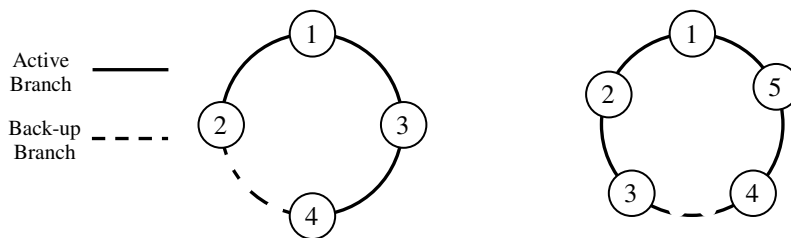

FIGURE 26: RING TOPOLOGY

OPTICAL SYSTEMS DESIGN

In Figure 26, node 1 will communicate with node 2, node 3 and node 4 via node 3. Node 2 will communicate to node 4 only via node 1 and 3.

In the event of a fiber link being broken or disconnected (indicated by a cross) the backup branch will become the active branch. If the link between node 1 and 3 is broken (see Figure 27), node 1 will communicate with node 3 via node 2 and node 4.

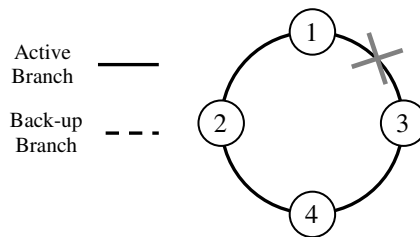

FIGURE 27: FLOAT BACKUP ENABLED 2

When the float backup is in enabled mode, if the broken or disconnected branch is re-established, the backup branch will now be the last broken/disconnected branch as shown in Figure 28.

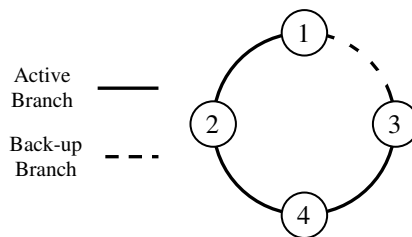

FIGURE 28: FLOAT BACKUP ENABLED 3

Note: When configuring the float backup function *all* units on the ring/bus network *must* have the same float backup configuration for correct operation. Differing backup configurations will cause segmented backup branches and may not function as intended.

All OSD2251P are set to **enabled** float backup upon shipment.

OPTICAL SYSTEMS DESIGN

FLOAT BACKUP DISABLE - <fbd>

```
fbd
-----
No.  MAC_ADDRESS          FLOAT_BACKUP  SETTING_RESULT
-----
1    00:26:dc:00:00:63      Disable      OK
2    00:26:dc:00:00:65      Disable      OK      <-local
3    00:26:dc:00:00:5f      Disable      OK
4    00:26:dc:00:00:64      Disable      OK

--- The end ---
$>
```

FIGURE 29: FLOAT BACKUP DISABLED 1

No: 4 – Lists number of units connected (in this case 1,2,3,4)

MAC_ADDRESS:– Displaying all the MAC addresses of the units connected on the ring/bus

FLOAT_BACKUP: Disable – Displays all the units connected to the ring/bus having Float Backup disabled.

SETTING_RESULT: OK – Displays the Float Backup disable has been successfully implemented.

<-local: This points to the unit that the USB cable is plugged into on the ring/bus.

The link furthest from the Master unit in a ring configuration is automatically selected as the backup branch. In the case of even units on a ring the fiber link on port 3 will always be the backup branch – indicated by a dashed line on a ring topology.

OPTICAL SYSTEMS DESIGN

In the event of a fiber link being broken or disconnected (indicated by a cross) the backup branch will become the active branch.

If the link between node 1 and 3 is broken (see Figure 30), node 1 will communicate with node 3 via node 2 and node 4.

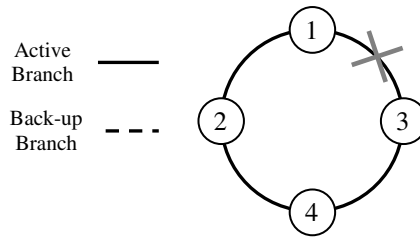

FIGURE 30: FLOAT BACKUP DISABLED 2

When the float backup is in disabled mode, if the broken or disconnected branch is re-established, the backup branch will again be the furthest link from the smallest MAC addressed unit as shown in Figure 31.

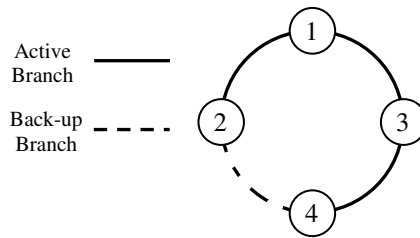

FIGURE 31: FLOAT BACKUP DISABLED 3

Note: When configuring the float backup function **all** units on the ring/bus network **must** have the same float backup configuration for correct operation. Differing backup configurations will cause segmented backup branches and may not function as intended.

All OSD2251P are set to **enabled** float backup upon shipment.

NODE IP SET - <node_ip_set>

```

node_ip_set
--- Help information ---
Four parameters are needed. Correct format is:
{node_ip_set/nis} <00:26:dc:xx:xx:xx>(hex) <ip address> <net mask> <gateway address>
For example: node_ip_set 00:26:dc:00:25:86 192.168.0.10 255.255.255.0 192.168.0.1
--- The end ---
$>

```

FIGURE 32: NODE IP SET

This command line enables the user to setup the IP of the node with the given MAC address. Correct entry format is as follows (MAC, IP, mask and gateway address specified below is an example);

node_ip_set 00:26:dc:00:1e:28 192.168.0.99 255.255.255.0 192.168.0.1

NODE ALL SET - <node_all_set>

```

$>node_all_set
--- Help information ---
Four parameters are needed. Correct format is:
{node_all_set/nas} <base ip address> <net mask> <gateway address> <step>
For example: node_all_set 192.168.0.10 255.255.255.0 192.168.0.1 2
Note: The base_ip_address is set on current device, the setting sequence follows
the display number when running tc command
Please make sure running tc command before executing this command
--- The end ---

```

FIGURE 33: NODE ALL CHECK

This command line enables the user to setup the IP for all nodes on a ring/bus. Correct entry format is as follows (MAC, IP, mask and gateway address specified below is an example);

node_all_set 192.168.0.99 255.255.255.0 192.168.0.1 2

2.6 WEB GUI

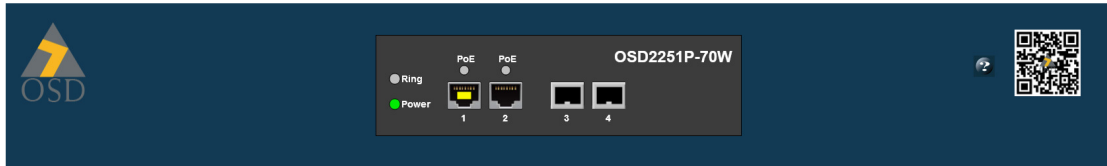

The OSD2251P provides a web-based browser interface for configuring and monitoring the unit. This interface allows you to access the switch using any preferred web browser.

This chapter describes how to configure the switch using its web-based browser interface.

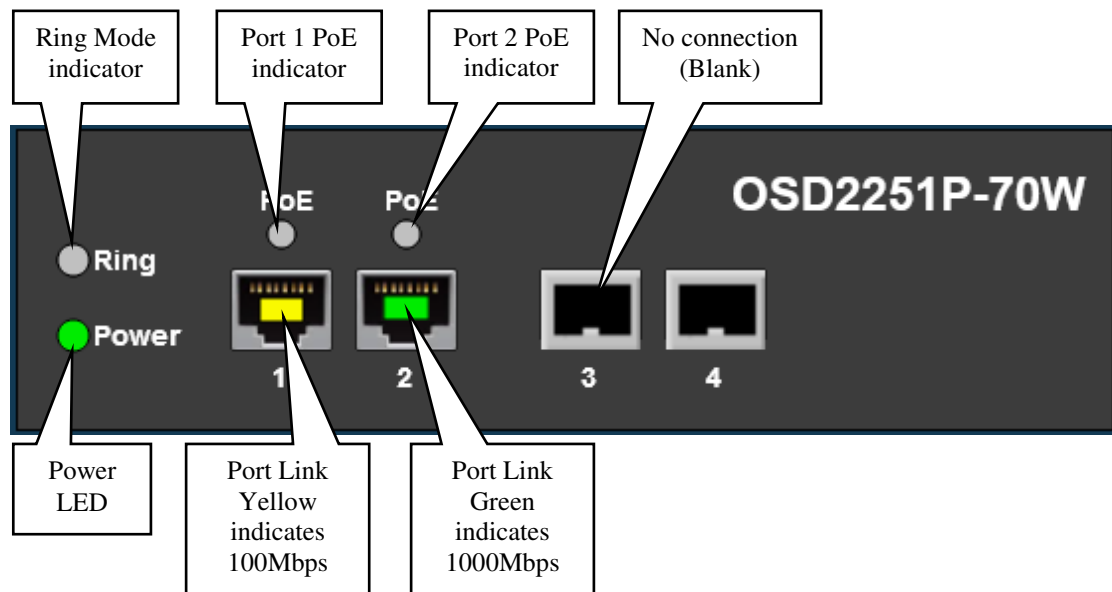

OPTICAL SYSTEMS DESIGN

2.6.1 LOGGING ON TO THE SWITCH

SWITCH IP ADDRESS

In your web browser, specify the IP address of the switch. Default IP address is 192.168.0.99

The screenshot shows the web interface for the OSD2251P-70W switch. The browser address bar shows 192.168.0.99. The interface includes a navigation menu on the left with options like Configuration, System, PoE, Port Setting, Monitor, System Info, Port, Topology, PoE, System Log, Maintenance, Upload, and System Reboot. The main content area displays a status dashboard with a QR code, a power indicator, and four port status indicators (PoE 1, PoE 2, Port 3, Port 4). Below the dashboard are three tables: Software Information, Hardware Information, and Running Information.

Parameter	Value
Software ID	600086-03
Build Time	31-01-2019:16:52:50

Parameter	Value
MAC address	00-26-dc-00-1e-28
Serial Number	10165960
PCB Number	844710-04
Date of Manufacture (DD-MM-YYYY)	14-02-2019

Parameter	Value
Running Hours	0 D: 0 H: 4 M: 40 S
Location	Not set
IP Address	192.168.0.99
Subnet Mask	255.255.255.0
Default Gateway	192.168.0.1
Temperature	29°C

Upon connecting to the OSD2251P, the home screen will display some useful information. The header will display the OSD2251P configuration (70W or 90W). Green lighted ports, Power and PoE indicate connection to relevant port and active state of Power and PoE Port1 and Port2.

A table displaying system information is also displayed containing MAC address, Serial Number, Software, IP address, etc.

Software Information

Parameter	Value
Software ID	600086-03
Build Time	31-01-2019:16:52:50

Hardware Information

Parameter	Value
MAC address	00-26-dc-00-1e-28
Serial Number	10165960
PCB Number	844710-04
Date of Manufacture (DD-MM-YYYY)	14-02-2019

Running Information

Parameter	Value
Running Hours	0 D: 0 H: 41 M: 0 S
Location	Not set
IP Address	192.168.0.99
Subnet Mask	255.255.255.0
Default Gateway	192.168.0.1
Temperature	29°C

2.6.2 GUI MENU

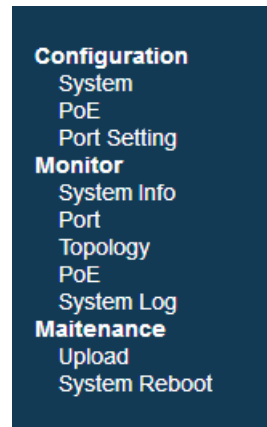

The user has access to Configure, Monitor or Maintain the OSD2251P. Each section will be explained within this manual.

OPTICAL SYSTEMS DESIGN

CONFIGURATION → SYSTEM

IP Configuration

	Configured	Current
IP Address	192.168.0.99	192.168.0.99
Subnet Mask	255.255.255.0	255.255.255.0
Default Gateway	192.168.0.1	192.168.0.1

Location

	Configured	Current
Location	Not set	Not set

IP ADDRESS

Configured: The IP address can be changed by modifying this window.

Current: Displays the current saved IP address

SUBNET MASK

Configured: The Subnet Mask can be changed by modifying this window.

Current: Displays the current saved Subnet Mask

DEFAULT GATEWAY

Configured: The Default Gateway can be changed by modifying this window.

Current: Displays the current saved Default Gateway

Buttons

: saves the new settings

: resets any changes made

OPTICAL SYSTEMS DESIGN

CONFIGURATION → PoE

PoE Configuration

Note: The maximum power limit setting for any given port is 70W. A higher input range will produce a maximum of 70W setting

Port	PoE Enabled	Manual Power Limitation Enabled	Configured Value (W)	Saved Value (W)	Legacy Device	Hi-PoE Device
1	<input checked="" type="checkbox"/>	<input type="checkbox"/>	-	-	<input type="checkbox"/>	<input type="checkbox"/>
2	<input checked="" type="checkbox"/>	<input type="checkbox"/>	-	-	<input type="checkbox"/>	<input type="checkbox"/>

1. Enable "Manual Power Limitation Enabled" where non-standard devices require greater power support. Enter the required power requirement in the "Configured Value" column in W.

2. To support legacy PoE devices, please enable "Legacy Device".

3. To support Hi-PoE devices "Manual Power Limitation Enabled" and "Hi-PoE Device" must be enabled. Enter the required power requirement in the "Configured Value" column in W.

PORT

Indicates port number per row.

POE ENABLED

A tick indicates the PoE is enabled for the port.

MANUAL POWER LIMITATION ENABLED

Allows the user to manually limit power in Watts (W) to each individual port. A tick indicates that the Manual Power Limitation is enabled.

CONFIGURED VALUE

If the Manual Power Limitation is enabled, the required Configured Value can be entered in this window. Note: The maximum configured power setting is as follows;

- 60W version: 70W. Entering a higher value produces a maximum of 70W only.
- 90W version: 90W. Entering a higher value produces a maximum of 90W only
- Note: Some PDs require very high inrush current (up to 1.6A). The power output configuration value must be set to maximum of 56W!

SAVED VALUE

If a previously saved Configured Value was entered, the value will be displayed in this window.

LEGACY DEVICE

The OSD2251P provides legacy PoE support. A tick will enable Legacy devices.

HI-POE DEVICE

To support Hi-PoE devices "Manual Power Limitation Enabled" and "Hi-PoE Support" must be enabled and the current (in mA) value in the "Configured Value" must be specified.

Buttons

: saves the new settings

: resets any changes made

OPTICAL SYSTEMS DESIGN

CONFIGURATION → PORT SETTING

Port Setting

Port	Mode
Port 1	Auto
Port 2	Auto

PORT

Indicates the Port number

MODE

Allows the user to set the Port Speed from the drop-down selection.

- **Auto:** Auto detection of the port speed
- **10Mbps HDX:** 10Mbps Half Duplex mode
- **10Mbps FDX:** 10Mbps Full Duplex mode
- **100Mbps HDX:** 100Mbps Half Duplex mode
- **100Mbps FDX:** 100Mbps Full Duplex mode
- **1Gbps FDX:** 1Gbps Full Duplex mode

Buttons

: saves the new settings

MONITOR → SYSTEM INFO

Software Information

Parameter	Value
Software ID	600086-03
Build Time	31-01-2019:16:52:50

Hardware Information

Parameter	Value
MAC address	00-26-dc-00-1e-28
Serial Number	10165960
PCB Number	844710-04
Date of Manufacture (DD-MM-YYYY)	14-02-2019

Running Information

Parameter	Value
Running Hours	0 D: 0 H: 41 M: 0 S
Location	Not set
IP Address	192.168.0.99
Subnet Mask	255.255.255.0
Default Gateway	192.168.0.1
Temperature	29°C

See Section 2.6.1

OPTICAL SYSTEMS DESIGN

MONITOR → PORT

Port Status

Port	Copper/SFP	Role	Link	Speed	Duplex
1	Copper	Switch Port	Up	100	Full
2	Copper	Switch Port	Down	-	-
3	SFP	Ring Port	Down	-	-
4	SFP	Ring Port	Down	-	-

PORT

Monitors each port activity.

COPPER/SFP

Indicates the port connection: Either Copper or SFP

ROLE

Switch Port: Indicates the role of the port

Ring Port: Indicates the role of the port

LINK

Up: Connection established

Down: No Connection detected

SPEED

Indicates the port connection speed in Mbps.

- **10:** 10Mbps
- **100:** 100Mbps
- **1000:** 1000Mbps (1Gbps)

DUPLEX

Indicates port connection type.

- **-:** No Connection
- **Half:** Half Duplex
- **Full:** Full Duplex

OPTICAL SYSTEMS DESIGN

MONITOR → TOPOLOGY

Ring Topology Status

No	MAC Address	Topology	Node Role	Ring_P0	Ring_P1	IP Address	Ring Version
1	00-26-dc-00-1e-28	INIT	SLAVE	U_port	U_port	192.168.0.99	5

No

Indicates number of units connected to the ring/bus

MAC ADDRESS

Lists the MAC address of the individual units connected on the ring/bus

TOPOLOGY

Indicates type of connection of the system

- **Init:** Only single unit connected
- **Ring:** Ring connection
- **Bus:** Bus Connection

NODE ROLE

Indicates the role of each unit on the ring/bus

- **Slave:** Slave
- **Master:** Master

RING_P0

Indicates the function of port 3 and its relation to the ring/bus

- **M_port:** Master Port (port facing the master)
- **S-port:** Slave Port (port back to the master)
- **B_port:** Backup Port
- **U_port:** Unconnected Port

RING_P1

Indicates the function of port 4 and its relation to the ring/bus

- **M_port:** Master Port (port facing the master)
- **S-port:** Slave Port (port back to the master)
- **B_port:** Backup Port
- **U_port:** Unconnected Port

IP ADDRESS

Lists the IP address of the individual units connected on the ring/bus

RING VERSION

Lists number of units on ring

OPTICAL SYSTEMS DESIGN

MONITOR → PoE

PoE Status

Port	Channel	Current	Voltage	Power	Current Limit	PD Class
1	ch0	-	-	-	-	-
	ch1	-	-	-	-	-
2	ch0	-	-	-	-	-
	ch1	-	-	-	-	-

PORT

Indicates port number per row.

CHANNEL

Indicates the channel number of the port

- **Ch0:** Pins 1,2 and Pins 3,6 on RJ45
- **Ch1:** Pins 4,5 and Pins 7,8 on RJ45

CURRENT

Indicates the current drawn from the relevant PoE port/channel

VOLTAGE

Indicates the voltage from the relevant PoE port/channel

POWER

Indicates the power drawn from the relevant PoE port/channel

CURRENT LIMIT

Indicates the maximum current limit from the relevant PoE port/channel

PD CLASS

Indicates the detected PD class.

OPTICAL SYSTEMS DESIGN

MONITOR → LOG

System Log Information

ID	Time	Logs
3	0 D: 0 H: 0 M: 30 S	Port 1 link up.
2	0 D: 0 H: 0 M: 0 S	Device boot up(0).
1	0 D: 0 H: 0 M: 1 S	Device boot up(0).

Monitors and logs activity

ID

Event number

TIME

Records a time-stamp of the log activity

LOGS

A brief description of the type of event

MAINTANANCE → UPLOAD

Software Upload

No file selected.

Use this section to upload OSD released update software.

Buttons

: Browse file location

: Upload software

MAINTANANCE → SYSTEM REBOOT

System Reboot

Use this section to reboot the unit

Buttons

: Reboots the unit

3 MAINTENANCE

3.1 INTRODUCTION

The following section outlines the fault-finding procedure for the OSD2251P modems. Please take note of the following:

- ▲ Personnel without appropriate training should not attempt any maintenance except that outlined below.
- ▲ If further maintenance is attempted you are warned that every care should be taken to ensure that internal measurements made while the equipment is operational are taken carefully as some components within the unit are expensive and may be damaged by failure of any portion of their support circuitry.
- ▲ Some components within the unit are Electrostatic (ES) sensitive and Electrostatic Discharge (ESD) precautions should be taken when performing maintenance upon the unit.

3.2 EXTERNAL INSPECTION

Visually check for the following:

- ▲ Check that the correct power source is connected to the power socket.
- ▲ Check that the Ethernet cables are connected to the modem correctly and that the distant OSD2251P modem has been connected correctly to any external equipment.
- ▲ Inspect the optical connectors (for fiber SFP option) for any contamination and clean using isopropyl alcohol and a lint free tissue if any contamination is detected.

3.3 ROUTINE MAINTENANCE

- ▲ There is no routine maintenance required with the OSD2251P.

4 WARRANTY

Thank you for purchasing equipment designed, manufactured and serviced by Optical Systems Design (OSD). OSD warrants that at the time of shipment, its products are free from defects in material and workmanship and conforms to specifications. Our Warranty conditions are outlined below:

4.1 WARRANTY PERIOD

For warranty period, please contact your local OSD distributor.

4.2 REPAIRS

Optical Systems Design reserves the right to repair or replace faulty modules/units. Please obtain a "Return Material Authorisation" (RMA) form and number before returning goods.

Goods must be returned in adequate packing material to Optical Systems Design, Warriewood or its nominated authorised representative, for all repairs.

4.2.1 WARRANTY REPAIRS

Return shipments to OSD shall be at customer's expense and freight back to the customer will be at OSD expense.

4.2.2 OUT-OF-WARRANTY REPAIRS

OSD reserves the right to repair or replace any faulty goods. Freight costs and insurance for both journeys are met by the user. All equipment repaired by OSD will have a 3-Month Warranty from the date of dispatch.

4.2.3 SITE REPAIRS

By agreement site repairs may be undertaken for which out of pocket, hotel and travel expenses will be charged.

4.2.4 EXCLUSIONS

This warranty does not apply to defects caused by unauthorized modifications, misuse, abuse or transport damage to the equipment. All modifications to OSD's standard product will need written authorization and will be charged at normal repair rates. All modifications are to be carried out by OSD Technicians. Warranty is void if unauthorized removal and/or tampering with serial number and/or repair labels is evident.

OPTICAL SYSTEMS DESIGN

OPTICAL SYSTEMS DESIGN

Optical Systems Design Pty. Ltd.
7/1 Vuko Pl. Warriewood 2102
P.O. Box 891 Mona Vale
N.S.W. Australia 2103
Telephone: +61 2 9913 8540
Facsimile: +61 2 9913 8735
Email: sales@osd.com.au
Web Site: www.osd.com.au

OPTICAL 
SYSTEMS
DESIGN

PTY LTD

A.B.N. 83 003 020 504

Printed in Australia