

---

**OPTICAL**

---

**SYSTEMS**

---

**DESIGN**

---

**OPERATOR MANUAL**

**OSD8828 SERIES**

**DIGITAL VIDEO AND DATA PAIR**

**FIBER OPTIC TRANSMISSION SYSTEM**



# OPTICAL SYSTEMS DESIGN

## INDEX 1

<b>1</b>	<b>TECHNICAL SUMMARY</b> .....	<b>4</b>
1.1	BRIEF DESCRIPTION .....	4
1.1.1	OVERVIEW .....	4
1.1.2	APPLICATIONS .....	4
1.1.3	FEATURES AND BENEFITS .....	4
1.2	TYPICAL CONFIGURATION .....	5
1.3	TECHNICAL SPECIFICATIONS .....	6
<b>2</b>	<b>INSTALLATION AND OPERATION</b> .....	<b>7</b>
2.1	INTRODUCTION .....	7
2.2	INSTALLATION .....	7
2.2.1	WARNING AND PRECAUTIONS .....	7
2.2.2	OSD8828 DRAWINGS AND DIMMENSIONS .....	8
2.3	PIN ASSIGNMENTS AND CONNECTIONS .....	9
2.4	DATA MODE SWITCH SETTINGS .....	11
2.5	CONNECTIONS .....	12
2.5.1	POWER SUPPLY CONNECTIONS .....	12
2.5.2	BASIC CONNECTIONS .....	12
2.5.3	CONTACT CLOSURE CONNECTIONS .....	12
2.6	OSD8828 OPERATION .....	13
2.6.1	OSD8828T AND OSD8828R OPERATION .....	13
2.6.2	OSD8828T AND OSD8828R INDICATORS .....	13
<b>3</b>	<b>MAINTENANCE</b> .....	<b>14</b>
3.1	INTRODUCTION .....	14
3.2	EXTERNAL INSPECTION .....	14
3.3	ROUTINE MAINTENANCE.....	14
<b>4</b>	<b>WARRANTY</b> .....	<b>15</b>
4.1	WARRANTY PERIOD .....	15
4.2	REPAIRS .....	15
4.2.1	WARRANTY REPAIRS .....	15
4.2.2	OUT-OF-WARRANTY REPAIRS .....	15
4.2.3	SITE REPAIRS .....	15
4.2.4	EXCLUSIONS .....	15
	FIGURE 1: OSD8828 TYPICAL CONFIGURATIONS .....	5
	FIGURE 2: OSD8828 MOUNTING DIMENSIONS.....	8
	FIGURE 3: DATA CONNECTOR PINOUTS .....	10
	FIGURE 4: DATA CABLING CONNECTIONS .....	10
	FIGURE 5: DATA SWITCH DIAGRAMS .....	11
	FIGURE 6: OSD8828T CONTACT CLOSURE INPUT .....	12
	FIGURE 7: OSD8828R CONTACT CLOSURE OUTPUT .....	12
	FIGURE 8: OSD8828T AND OSD8828R LED INDICATORS .....	13
	TABLE 1: TECHNICAL SPECIFICATIONS .....	6
	TABLE 2: PIN ASSIGNMENT .....	9
	TABLE 3: DATA MODE SWITCH SETTINGS .....	11
	TABLE 4: DATA SWITCH EXAMPLES .....	11
	TABLE 5: OSD8828 INDICATOR FUNCTION .....	13

## 1 TECHNICAL SUMMARY

### 1.1 BRIEF DESCRIPTION

#### 1.1.1 OVERVIEW

The OSD8828 series is a high-quality fiber optic digital video and data transmission system. The system consists of the OSD8828T and the OSD8828R, which are designed to be used as a pair, and provide one-way transmission of PAL, NTSC or SECAM video, plus full-duplex transmission of one data channel and forward path transmission of a contact closure.

The OSD8828T accepts one analog composite video input signal along with one digital data input signal. The video signal is converted to digital with 10-bit resolution so as to preserve the quality of the input signals. The resulting digital signal is multiplexed and transmitted as a digital bit-stream through the fiber. The OSD8828T also includes an optical receiver section that decodes the digital signal transmitted by the OSD8828R, to provide data output signals. Data can be TTL, RS232, RS485 or RS422 31kHz Manchester or Bi-phase. The OSD8828T receiver provides adjustment free operation over the full optical range of the unit.

The OSD8828R incorporates a high performance optical digital receiver for incoming video and data signals, and a transmitter that outputs a digital optical signal consisting of one data channel. The unit provides a constant video output level which is independent of link loss, and data section of the OSD8828R is also adjustment free over all link lengths.

The OSD8828T and OSD8828R are available in 2RU card configuration. They are designed to fit the 2RU-high 19" OSD3700 chassis, which allows multiple 2RU OSD card products to be conveniently powered from and located in the one chassis.

The OSD8828 system can be used with any standard singlemode or multimode optical fiber over a single fiber for transmission and reception.

#### 1.1.2 APPLICATIONS

- ▲ High quality CCTV networks requiring full duplex or reverse data transmission between cameras and their control centre
- ▲ Safe city projects
- ▲ Transportation communication systems

#### 1.1.3 FEATURES AND BENEFITS

- ▲ One way optic transmission of PAL, NTSC or SECAM video plus one duplex transmission of one data channel and one forward path transmission of a contact closure for tamper alarms.
- ▲ Up to 18 units plug into the OSD3700 2RU high 19" rack mounting enclosure
- ▲ Broadcast quality 10 bit video maintained over all link lengths.
- ▲ Operating range of at least 5km on multimode and 40km on singlemode fiber, with longer distances possible using optional optical devices
- ▲ Video bandwidth of 6MHz
- ▲ Standard operation using multimode or singlemode fiber: no need to specify fiber type
- ▲ Remote control of Pan, Tilt and Zoom for video surveillance
- ▲ Single fiber operation
- ▲ Units are completely compatible with the OSD8826T and OSD8826R cards and modules

# OPTICAL SYSTEMS DESIGN

## 1.2 TYPICAL CONFIGURATION

Figure 1 below indicates the typical set-up for an OSD8828 system.

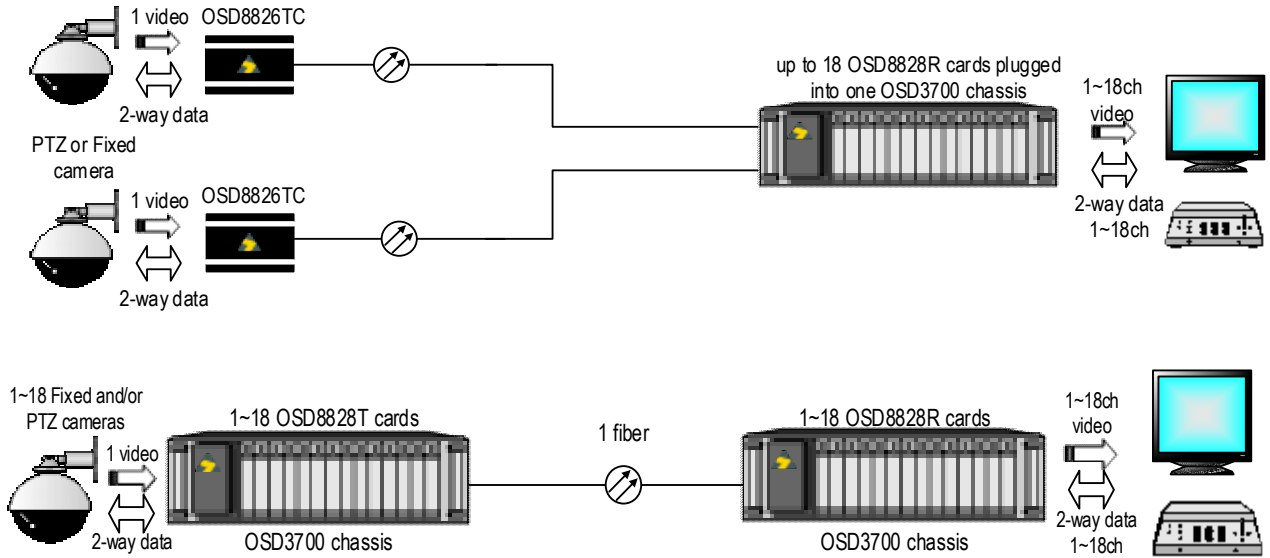

FIGURE 1: OSD8828 TYPICAL CONFIGURATIONS

The OSD8828T and OSD8828R pair can provide one forward video transmission and full duplex data transmission between camera (transmitter) and monitoring site (receiver).

# OPTICAL SYSTEMS DESIGN

## 1.3 TECHNICAL SPECIFICATIONS

TABLE 1: TECHNICAL SPECIFICATIONS

SPECIFICATION	PERFORMANCE
Video Input/Output Impedance	75Ω
Video Input/Output Levels	1Vpp nominal
Video Connectors	BNC
Video Bandwidth	5Hz to 6MHz
Signal to Noise Ratio (Weighted)	> 63dB
Linearity	<1% Differential Phase (DP) <1° Differential Gain (DG)
Data Interface	TTL, RS232, RS422 and RS485. 31kHz Manchester or Biphasic possible in either direction
Data Rates	DC to > 1.0Mbps
Contact Transmission	Buffered input at OSD8828T, MOSFET output at OSD8828R
Data Connectors	8 Way cage clamp terminal block
Number of Fibers Required	One only
OSD8828T Transmitter Wavelength	1310nm
OSD8828T Transmitter Coupled Power	-14 to -4dBm into singlemode fiber -11 to -1dBm into multimode fiber
OSD8828R Transmitter Wavelength	1550nm
OSD8828R Transmitter Coupled Power	-15 to -4dBm into singlemode -12 to -1dBm into multimode fiber
OSD8828R Receiver Sensitivity	<-33dBm
OSD8828R Receiver Saturation	>-3dBm
OSD8828T Receiver Sensitivity	<-36dBm (singlemode fiber)
OSD8828T Receiver Saturation	>-3dBm
Optical Connector	ST standard, SC and FC optional
Optical Link Budget and distances	>21dB: >5km on multimode fiber @ 1310nm (fiber bandwidth limited) >18dB: >40km on singlemode fiber @ 1310nm (fiber loss limited) >30dB: >80km on singlemode fiber @ 1310nm with high power devices*
Dimensions (mm)	20W x 216D x 70H
Weight	200g
Power Requirements	+10V to +40V <sub>DC</sub> (12V <sub>DC</sub> supplied by OSD9221)
Operating Temperature	-40°C to +75°C
Relative Humidity	0 to 95% non-condensing
Chassis Current Consumption (CCC)	0.2 Amp

102882802

NOTES:

\*Other combinations of laser types and optical levels, receiver types and sensitivity levels are possible. Contact OSD for details.

## 2 INSTALLATION AND OPERATION

### 2.1 INTRODUCTION

This section outlines the methods required to install and operate the OSD8828T and OSD8828R successfully. It should be studied carefully if damage to the equipment or poor results are to be avoided. This equipment has been fully tested prior to dispatch and is ready for immediate operation. However it is advisable to check for external transportation damage before operation. If damage is evident, return the unit with the packaging to your supplier immediately.

### 2.2 INSTALLATION

#### 2.2.1 WARNING AND PRECAUTIONS

##### ▲ ELECTROMAGNETIC COMPATIBILITY

**WARNING:** This is a Class A product. In a domestic environment this product may cause radio interference in which case the user may be required to take adequate measures.

##### ▲ OPTICAL OUTPUT OPERATION

**WARNING: Laser Safety:** Class 1 Laser Product per IEC/EN 60825-1:20011 standard.

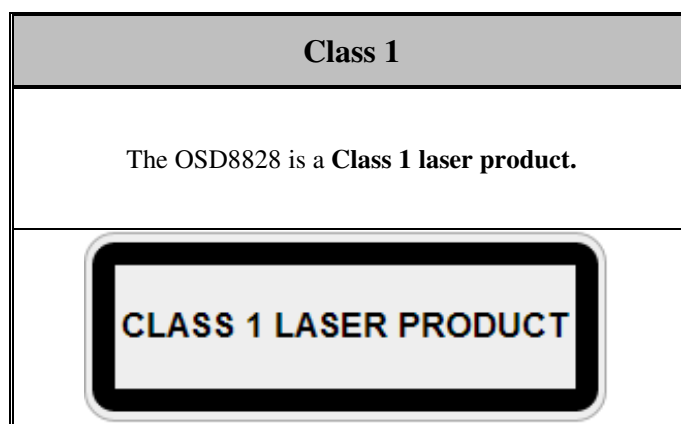

#### PRECAUTIONS

- ▲ All service personnel should be provided training as to the hazards of direct viewing of laser radiation and of the precautionary measures during servicing of equipment
- ▲ Areas where laser products are installed should be restricted in access to trained service personnel only and appropriate warning signs posted in the work area.
- ▲ All laser apertures should be covered by protective covers when not connected to optical fibers. Never leave outputs uncovered.
- ▲ Laser equipment should be positioned above or below eye level where possible. Apertures should be positioned away from personnel.
- ▲ Protective eyewear should be worn in the vicinity of laser equipment.

# OPTICAL SYSTEMS DESIGN

## 2.2.2 OSD8828 DRAWINGS AND DIMENSIONS

The OSD8828T and OSD8828R cards are designed to be inserted into a 2RU OSD3700 chassis and secured by means of captivated screws.

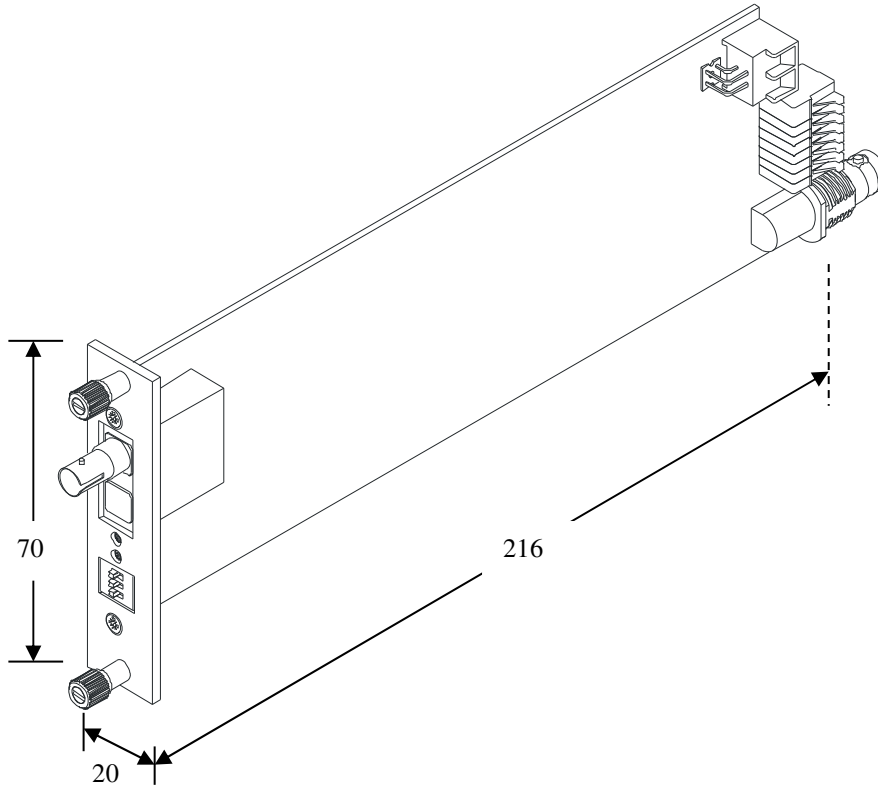

FIGURE 2: OSD8828 MOUNTING DIMENSIONS



# OPTICAL SYSTEMS DESIGN

## 2.3 PIN ASSIGNMENTS AND CONNECTIONS

Pin assignments for the “Data Input/Output” connectors (Figure 3) are shown in Table 2 below. The OSD8828 cards have an 8 way cage clamp terminal block connector located on the rear. Shielded cables are recommended for video and data wiring.

TABLE 2: PIN ASSIGNMENT

PIN	FUNCTION	PIN	FUNCTION
1	Data Input +	5	RS232 Input
2	Data Input –	6	RS232 Output
3	Data Output + / RS485 2W DI/O+	7	Contact Closure
4	Data Output - / RS485 2W DI/O-	8	Data Ground

### RS422 / 4W RS485

Pin	Connection
1	Rx +
2	Rx –
3	Tx +
4	Tx –
8	Ground

### 2W RS485

Pin	Connection
3	I/O +
4	I/O –
8	Ground

### Contact Closure OSD8828T

Pin	Connection
7	Contact Input
8	Ground

### OSD8828R

Pin	Connection
7	Normally open (NO)
8	Common (COM)

**RS485 2-Wire** half duplex is used to connect several devices to the same bus when only one unit transmits data at a time. All units are normally in high impedance receive mode waiting for data. When transmission of data is requested, the unit waits for a protocol specific turn-around time delay before transmitting after which it returns to receive mode.

**RS485 4-Wire** full duplex is used for master/slave arrangement. Devices are polled and respond faster with no turn-around time delay required between request/response. The receiver is always enabled allowing the devices to receive data even while responding to a request.

**Note:** If a link doesn't seem to be working correctly, try swapping the polarity of the data lines on both ends. Some devices are marked opposite the RS485 standard.

# OPTICAL SYSTEMS DESIGN

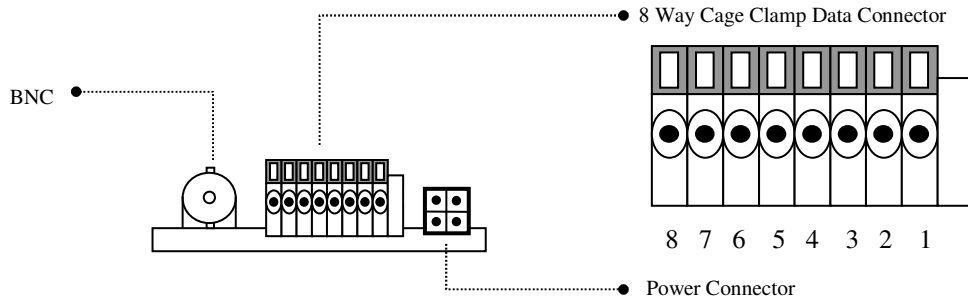

FIGURE 3: DATA CONNECTOR PINOUTS

To connect data cabling for the 8 way cage clamp terminal block, strip the wire between 8mm to 12mm in length. Insert the cable into the appropriate slot. Using a flat head screw driver, push the orange latch that is above the cable being inserted and push the cable further in. Release the orange latch. Gently pull the cable to ensure it is connected and does not come out. If it does come out, the wire is not stripped enough. Note that if the wire is stripped less than 7mm, there will not be a secure connection. Shielded cables are recommended for video and data wiring.

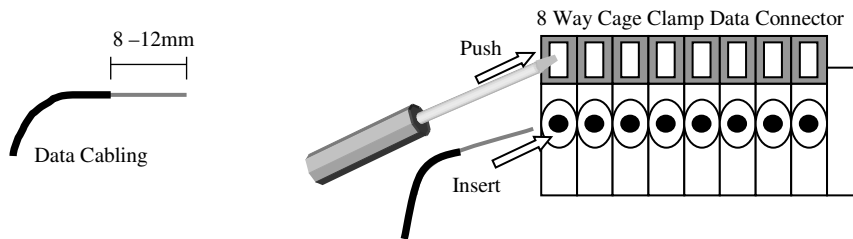

FIGURE 4: DATA CABLING CONNECTIONS

# OPTICAL SYSTEMS DESIGN

## 2.4 DATA MODE SWITCH SETTINGS

The 3-way data control switch is located at the front of OSD8828 modem. Switches SW1, SW2 and SW3 are used for setting the Data Mode Options.

**Note:** For correct operation, ensure that both OSD8828T and OSD8828R have the switch settings in the same modes.

TABLE 3: DATA MODE SWITCH SETTINGS

SWITCH	STATE	POSITION	FUNCTION
SW1	OFF	DOWN	RS422/485
	ON	UP	RS232
SW2	OFF	DOWN	4-Wire Operation
	ON	UP	2-Wire Operation
SW3	OFF	DOWN	RS422
	ON	UP	RS485

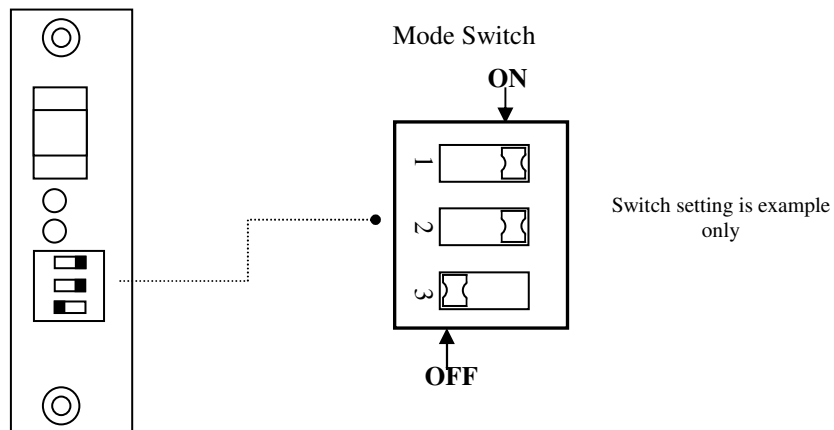

FIGURE 5: DATA SWITCH DIAGRAMS

TABLE 4: DATA SWITCH EXAMPLES

DATA TYPE	SW1	SW2	SW3
RS232	1	X	X
RS422	0	X	0
RS485 2W	0	1	1
RS485 4W	0	0	1

1=On, 0=Off, X=Don't Care

# OPTICAL SYSTEMS DESIGN

## 2.5 CONNECTIONS

### 2.5.1 POWER SUPPLY CONNECTIONS

The OSD8828 card version is powered from the OSD3700 2RU chassis. DC power in the OSD8828 card version is connected via 4-way PCB mounting plug connector. The card version of the OSD8828T and OSD8828R should be fixed into the OSD3700 chassis using the captivated screws. Either card can be plugged in or out of the OSD3700 chassis with power on or off.

### 2.5.2 BASIC CONNECTIONS

The video-input signal (eg. from camera) is connected to the video input BNC connector on the OSD8828T. The video output signal (eg. to monitor) is connected from the video output BNC connector on the OSD8828R.

Data signals are connected to the 8 way cage clamp terminal block connector as set out in Table 2.

Shielded cables are recommended for video and data wiring.

The optical fiber cable must be terminated with the appropriate optical connector. Before connection, inspect the ends of the connectors to ensure that no dust or dirt is present as it could contaminate the modem connector and result in poor performance.

If it is necessary to clean the cable connectors, use isopropyl alcohol and lint free tissue to remove contamination.

### 2.5.3 CONTACT CLOSURE CONNECTIONS

The OSD8828 has one forward contact closure channel. The contact closure input on the OSD8828T (Pin 7) is driven high. To operate the contact closure, the input should be switched to ground (see Figure 6).

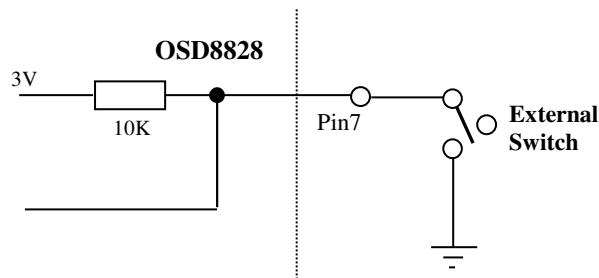

FIGURE 6: OSD8828T CONTACT CLOSURE INPUT

The contact closure output on the OSD8828R/RC/R2 (Pin 7) is to be connected to the relay coil. Maximum ratings the OSD8828 can drive is 1.5A @ 24V<sub>(max)</sub>.

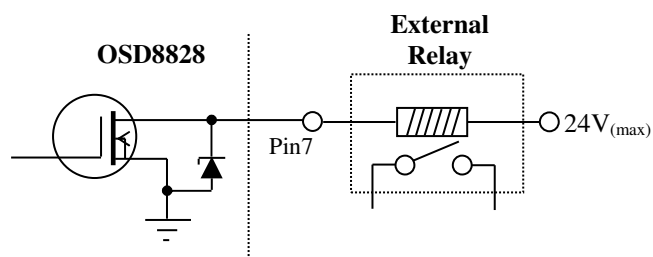

FIGURE 7: OSD8828R CONTACT CLOSURE OUTPUT

# OPTICAL SYSTEMS DESIGN

## 2.6 OSD8828 OPERATION

### 2.6.1 OSD8828T AND OSD8828R OPERATION

When using the OSD8828 for the first time, check that the unit is in good condition with no visible damage.

Insert the OSD8828 card in an appropriate slot on the OSD3700 chassis and check that the indicators illuminate accordingly on power up (see Table 5).

To connect a video signal, connect a BNC terminated coaxial cable from the camera to the OSD8828T. If the camera is operational, the "Video Present" indicator should illuminate 'Amber'.

Connect a BNC terminated coaxial cable between the BNC socket on the rear of the OSD8828R and the video monitor or switcher.

Plug in the optical connectors of the optical cable. If the set-up is connected correctly, the OSD8828R "Link OK" LED will change from 'Red' to 'Green'. If a video signal is being received the "Video Present" indicator on the OSD8828R should be 'Amber'; if no video signal is being received this indicator will not be illuminated.

Plug the digital signal source (data) into 8 way terminal block connector on the rear of the module.

Ensure that the correct signals are connected to the correct pins of Data Input/Output connector as specified in Table 2.

Ensure that both OSD8828T and OSD8828R switch settings are in the same modes (see Table 3).

### 2.6.2 OSD8828T AND OSD8828R INDICATORS

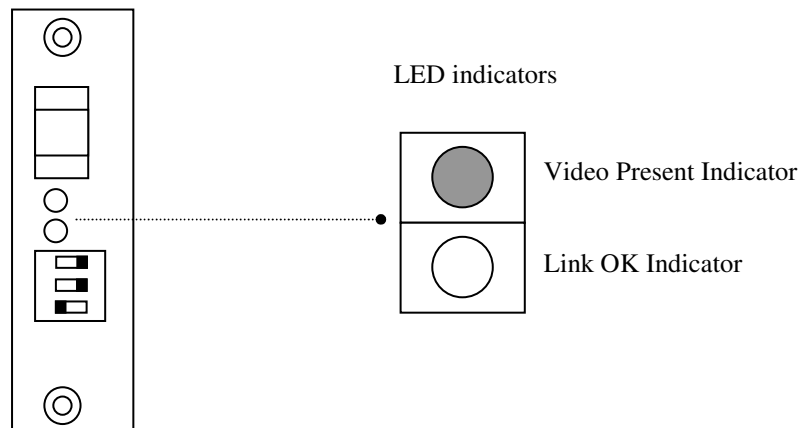

FIGURE 8: OSD8828T AND OSD8828R LED INDICATORS

TABLE 5: OSD8828 INDICATOR FUNCTION

INDICATOR	PARAMETER	COLOUR	FUNCTION
VIDEO PRESENT	Video Input Status	Off	No video signal present
		Amber	Video signal present
LINK OK	Link Status	Red	No optical signal received
		Green	Optical Signal received

## 3 MAINTENANCE

### 3.1 INTRODUCTION

The following section outlines the fault-finding procedure for the OSD8828T and OSD8828R modems. Please take note of the following:

- ▲ Personnel without appropriate training should not attempt any maintenance except that outlined below.
- ▲ If further maintenance is attempted you are warned that every care should be taken to ensure that internal measurements made while the equipment is operational are taken carefully as some components within the unit are expensive and may be damaged by failure of any portion of their support circuitry.
- ▲ Some components within the unit are Electrostatic (ES) sensitive and Electrostatic Discharge (ESD) precautions should be taken when performing maintenance upon the unit.

### 3.2 EXTERNAL INSPECTION

Visually check for the following:

- ▲ Check that the correct power source is connected to the power socket.
- ▲ Check that the data signals are connected to the modem correctly and that the distant OSD8828T or OSD8828R modem has been terminated correctly to any external equipment.
- ▲ Inspect the optical connectors for any contamination and clean using isopropyl alcohol and a lint free tissue if any contamination is detected.
- ▲ Check that any external termination resistors are connected if the system configuration requires them.

### 3.3 ROUTINE MAINTENANCE

- ▲ There is no routine maintenance required with the OSD8828T and OSD8828R.

## 4 WARRANTY

Thank you for purchasing equipment designed, manufactured and serviced by Optical Systems Design (OSD). OSD warrants that at the time of shipment, its products are free from defects in material and workmanship and conforms to specifications. Our Warranty conditions are outlined below:

### 4.1 WARRANTY PERIOD

For warranty period, please call your local OSD distributor.

### 4.2 REPAIRS

Optical Systems Design reserves the right to repair or replace faulty modules/units. Please obtain a "Return Material Authorisation" (RMA) form and number before returning goods.

Goods must be returned in adequate packing material to Optical Systems Design, Warriewood or its nominated authorised representative, for all repairs.

#### 4.2.1 WARRANTY REPAIRS

Return shipments to OSD shall be at customer's expense and freight back to the customer will be at OSD expense.

#### 4.2.2 OUT-OF-WARRANTY REPAIRS

OSD reserves the right to repair or replace any faulty goods. Freight costs and insurance for both journeys are met by the user. All equipment repaired by OSD will have a 3-Month Warranty from the date of dispatch.

#### 4.2.3 SITE REPAIRS

By agreement site repairs may be undertaken for which out of pocket, hotel and travel expenses will be charged.

#### 4.2.4 EXCLUSIONS

This warranty does not apply to defects caused by unauthorized modifications, misuse, abuse or transport damage to the equipment. All modifications to OSD's standard product will need written authorization and will be charged at normal repair rates. All modifications are to be carried out by OSD Technicians. Warranty is void if unauthorized removal and/or tampering with serial number and/or labels is evident.

---

Optical Systems Design Pty. Ltd.

7/1 Vuko Pl. Warriewood 2102

P.O. Box 891 Mona Vale

N.S.W. Australia 2103

Telephone: +61 2 9913 8540

Facsimile: +61 2 9913 8735

Email: [sales@osd.com.au](mailto:sales@osd.com.au)

Web Site: [www.osd.com.au](http://www.osd.com.au)

---

---

OPTICAL

---

SYSTEMS

---

DESIGN

---

PTY LTD

A.B.N. 83 003 020 504

Printed in Australia