OPTICAL

SYSTEMS

DESIGN

OPERATOR MANUAL

OSD361

FIBER OPTIC CCTV

TRANSMITTER MODULE

OPTICAL SYSTEMS DESIGN

OSD361

FIBER OPTIC CCTV

TRANSMITTER MODULE

Document No. 10102303

OPTICAL SYSTEMS DESIGN

INDEX 1

1	TECHNICAL SUMMARY.....	3
1.1	BRIEF DESCRIPTION.....	3
1.1.1	OVERVIEW.....	3
1.1.2	APPLICATIONS.....	3
1.1.3	FEATURES AND BENEFITS.....	3
1.2	TYPICAL CONFIGURATION.....	4
1.3	PRODUCTS AND OPTIONS.....	4
1.4	TECHNICAL SPECIFICATIONS.....	5
2	INSTALLATION AND OPERATION.....	6
2.1	INTRODUCTION.....	6
2.2	INSTALLATION.....	6
2.2.1	WARNING AND PRECAUTIONS.....	6
2.2.2	OSD361 DRAWINGS AND DIMENSIONS.....	7
2.2.3	POWER SUPPLY CONNECTIONS.....	8
2.2.4	SIGNAL CONNECTIONS.....	8
2.2.5	INDICATOR.....	8
3	MAINTENANCE.....	9
3.1	INTRODUCTION.....	9
3.2	EXTERNAL INSPECTION.....	9
3.3	ROUTINE MAINTENANCE.....	9
4	WARRANTY.....	10
4.1	WARRANTY PERIOD.....	10
4.2	REPAIRS.....	10
4.2.1	WARRANTY REPAIRS.....	10
4.2.2	OUT-OF-WARRANTY REPAIRS.....	10
4.2.3	SITE REPAIRS.....	10
4.2.4	EXCLUSIONS.....	10
	FIGURE 1: TYPICAL CONFIGURATIONS.....	4
	FIGURE 2: OSD361 CASE DIMENSIONS.....	7
	FIGURE 3: OSD361 SIDE VIEWS.....	8
	TABLE 1: PRODUCTS AND OPTIONS.....	4
	TABLE 2: TECHNICAL SPECIFICATIONS.....	5

1 TECHNICAL SUMMARY

1.1 BRIEF DESCRIPTION

1.1.1 OVERVIEW

The OSD361 is a small, self-contained, fiber-optic video transmitter module. Two basic configurations are available: the OSD361 is designed for use with multimode fiber and transmits at 850nm, while the OSD361L is designed for use with singlemode fiber and transmits at 1310nm. A one-way fiber-optic video transmission link formed by using the OSD361 with one of the OSD300 series fiber-optic receiver modules will provide CCTV or better quality video transmission at distances of over 5km using standard low cost multimode optical fiber. Using the OSD361L and singlemode fiber, distances of over 30km can be spanned.

1.1.2 APPLICATIONS

- ▲ Short distance surveillance links
- ▲ Medical imaging
- ▲ Industrial process monitoring

1.1.3 FEATURES AND BENEFITS

- | | |
|---|---|
| ▲ Extremely cost effective | ▲ Complete end to end isolation |
| ▲ Bandwidth of 8MHz | ▲ More secure than copper cables |
| ▲ Extends wideband video transmission to over 3km | ▲ Small size, low cost, robust and reliable |
| ▲ Immune to electrical noise | ▲ Safe transmission in hazardous environments |

OPTICAL SYSTEMS DESIGN

1.2 TYPICAL CONFIGURATION

Figure 1 below indicates a possible set-up for an OSD361.

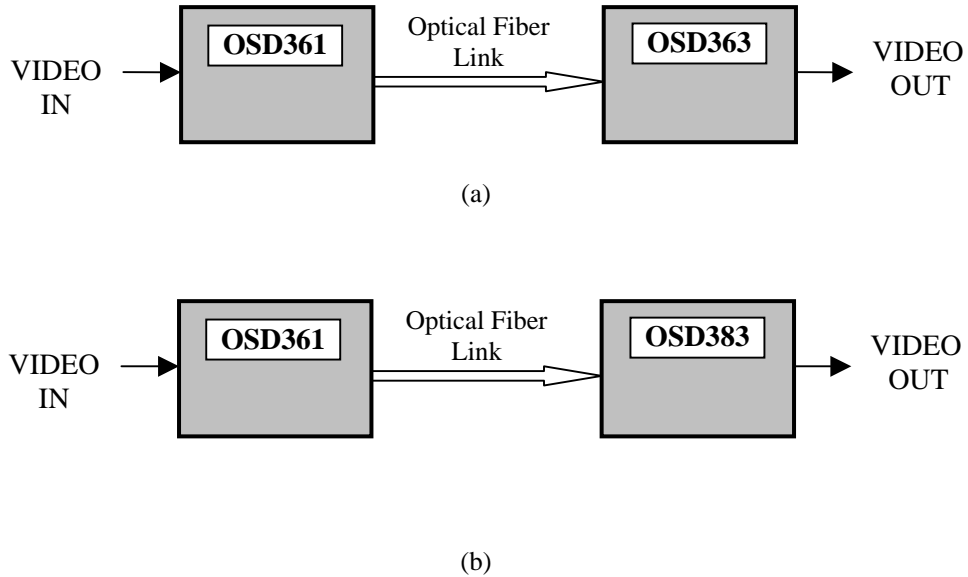

FIGURE 1: TYPICAL CONFIGURATIONS
(a) OSD361 to OSD363, (b) OSD361 to OSD383.

1.3 PRODUCTS AND OPTIONS

There are various options available for the OSD361 as identified in Table 1 below:

TABLE 1: PRODUCTS AND OPTIONS

ITEM	DESCRIPTION
OSD361	STANDARD FIBER OPTIC CCTV TRANSMITTER MODULE
OSD361L	1300nm SINGLEMODE OPERATION CCTV TRANSMITTER MODULE
OSD902PP	MAINS INPUT PLUG PACK TO SUIT OSD361 PRODUCTS

OPTICAL SYSTEMS DESIGN

1.4 TECHNICAL SPECIFICATIONS

Table 2 below provides Technical Specifications for the OSD361.

TABLE 2: TECHNICAL SPECIFICATIONS

NO	SPECIFICATION	PERFORMANCE
1	Input Impedance	75Ω
2	Input Level	1Vp-p
3	Video Connector	BNC Socket
4	Power Connector	2-pin socket
5	Bandwidth	10Hz to 8MHz +1/-3dB
6	Weighted Signal to Noise Ratio	>50dB at -30dBm peak received optical power
7	Transmitter Wavelength	850 ± 40nm (multimode) 1300 ± 40nm (singlemode)
8	Transmitter Coupled Power	>-16dBm peak into 62.5/125um multimode fiber >-20dBm peak into 10/125um singlemode fiber (OSD361L only)
9	Optical Connectors	ST standard, others optional
10	Power Requirements	+9V _{DC} to +18V _{DC} 6V _{AC} to 15V _{AC} at 100mA max
11	Enclosure	Strong metal case
12	Indicators	Power On
13	Dimensions (mm)	93D x 54W x 28H (excludes flanges and optical connectors)
14	Weight of Module (kg)	0.25
15	Operating Temperature	-20 to 75°C
16	Relative Humidity	0 to 95% non-condensing

2 INSTALLATION AND OPERATION

2.1 INTRODUCTION

This section outlines the methods required to install and operate the OSD361 successfully. It should be studied carefully if damage to the equipment or poor results are to be avoided.

This equipment has been fully tested prior to dispatch and is ready for immediate operation. However it is advisable to check for external transportation damage before operation. If damage is evident, return the unit with the packaging to your supplier immediately.



2.2 INSTALLATION

2.2.1 WARNING AND PRECAUTIONS

ELECTROMAGNETIC COMPATIBILITY

WARNING: This is a **Class A** product. In a domestic environment this product may cause radio interference in which case the user may be required to take adequate measures.

OPTICAL OUTPUT OPERATION

Class 1	Class 3A
<p>The multimode version of the OSD361 is a Class 1 LED product. Wavelength of 850nm and <-8dBm power output.</p>	<p>The singlemode version of the OSD361 is a Class 3A laser product. Wavelength of 1310nm and <+5dBm power output or wavelength of 1550nm and <+7dBm power output.</p>
	

PRECAUTIONS

- ▲ All service personnel should be provided training as to the hazards of direct viewing of laser radiation and of the precautionary measures during servicing of equipment
- ▲ Areas where laser products are installed should be restricted in access to trained service personnel only and appropriate warning signs posted in the work area.
- ▲ All laser apertures should be covered by protective covers when not connected to optical fibers. Never leave outputs uncovered.
- ▲ Laser equipment should be positioned above or below eye level where possible. Apertures should be positioned away from personnel.
- ▲ Protective eyewear should be worn in the vicinity of laser equipment.

OPTICAL SYSTEMS DESIGN

2.2.2 OSD361 DRAWINGS AND DIMENSIONS

The OSD361 should be mounted on an even surface and secured by means of M4 or smaller screws.

Figure 2 is an outer case drawing showing the required mounting dimensions.

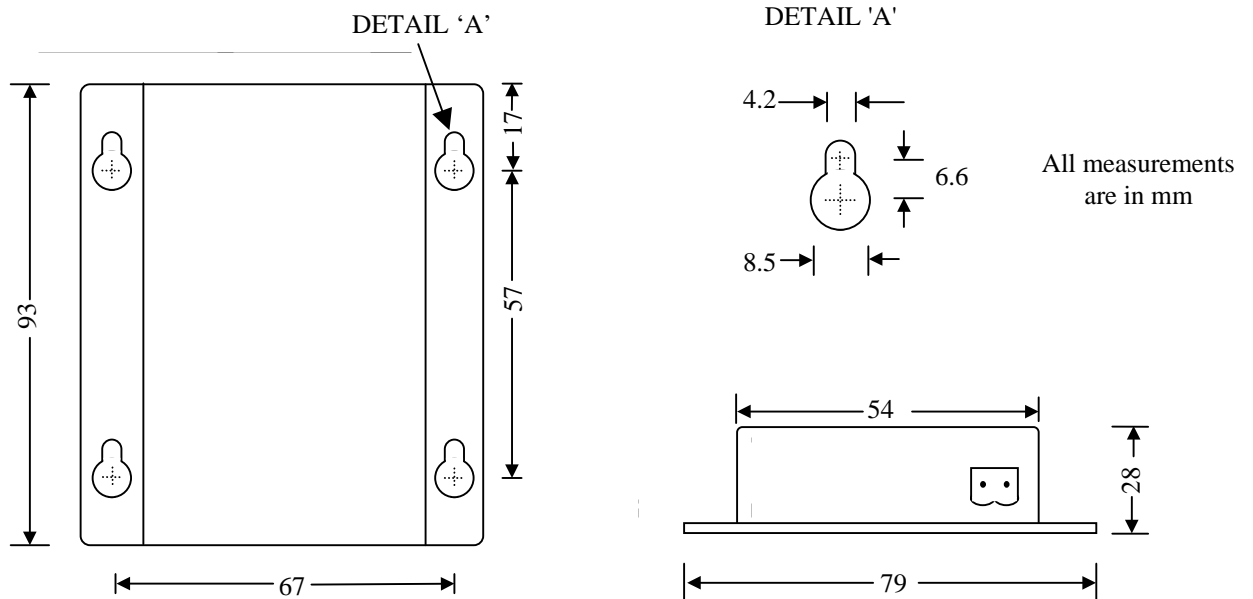

FIGURE 2: OSD361 CASE DIMENSIONS

OPTICAL SYSTEMS DESIGN

2.2.3 POWER SUPPLY CONNECTIONS

The OSD361 requires external DC or AC power. The acceptable DC voltage range is +9 to +18V DC, and the allowed AC voltage range is 6 to 15V AC, with maximum current draw of 100mA. Power should be connected to the 2 way socket located at the back of the case. Take care to connect DC power with the correct polarity: Pin 2 is ground and Pin 1 is positive power. For AC supplies the polarity is not applicable.

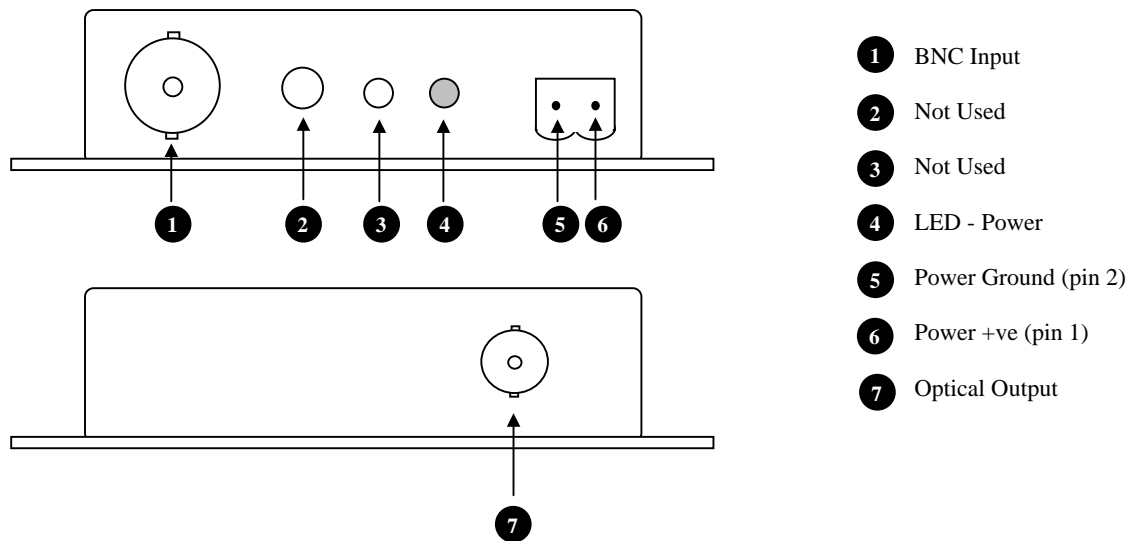

FIGURE 3: OSD361 SIDE VIEWS

2.2.4 SIGNAL CONNECTIONS

Video input signal should be connected to the female BNC connector on the OSD361 using 75Ω cable terminated in a male BNC connector.

The optical fiber cable must be terminated with the appropriate optical connector. Before connection, inspect the ends of the connectors to ensure that no dust or dirt is present as it could contaminate the modem connector and result in poor performance.

If it is necessary to clean the cable connectors use isopropyl alcohol and lint free tissue to remove contamination.

2.2.5 INDICATOR

The OSD361 has one LED indicator. The indicator will be 'green' to indicate that power to the unit is "on".

3 MAINTENANCE

3.1 INTRODUCTION

The following section outlines the fault-finding procedure for the OSD361 modems. Please take note of the following:

- ▲ Personnel without appropriate training should not attempt any maintenance except that outlined below.
- ▲ If further maintenance is attempted you are warned that every care should be taken to ensure that internal measurements made while the equipment is operational are taken carefully as some components within the unit are expensive and may be damaged by failure of any portion of their support circuitry.
- ▲ Some components within the unit are ES sensitive and ESD precautions should be taken when performing maintenance upon the unit.

3.2 EXTERNAL INSPECTION

Visually check for the following:

- ▲ Check that the correct power source is connected to the power socket.
- ▲ Check that the video signals are connected to the modem correctly and that the distant modem has been terminated correctly to any external equipment.
- ▲ Inspect the optical connectors for any contamination and clean using isopropyl alcohol and a lint free tissue if any contamination is detected.
- ▲ Check that any external termination resistors are connected if the system configuration requires them.

3.3 ROUTINE MAINTENANCE

- ▲ There is no routine maintenance required with the OSD361.

4 WARRANTY

Thank you for purchasing equipment designed, manufactured and serviced by Optical Systems Design (OSD). OSD warrants that at the time of shipment, its products are free from defects in material and workmanship and conforms to specifications. Our Warranty conditions are outlined below:

4.1 WARRANTY PERIOD

For warranty period, please call your local OSD distributor.

4.2 REPAIRS

Optical Systems Design reserves the right to repair or replace faulty modules/units. Please obtain a "Return Material Authorisation" (RMA) form and number before returning goods. Goods must be returned in adequate packing material to Optical Systems Design, Warriewood or its nominated authorised representative, for all repairs.

4.2.1 WARRANTY REPAIRS

Return shipments to OSD shall be at customer's expense and freight back to the customer will be at OSD expense.

4.2.2 OUT-OF-WARRANTY REPAIRS

OSD reserves the right to repair or replace any faulty goods. Freight costs and insurance for both journeys are met by the user. All equipment repaired by OSD will have a 3-Month warranty from the date of dispatch.

4.2.3 SITE REPAIRS

By agreement site repairs may be undertaken for which out of pocket, hotel and travel expenses will be charged.

4.2.4 EXCLUSIONS

This warranty does not apply to defects caused by unauthorized modifications, misuse, abuse or transport damage to the equipment. All modifications to OSD's standard product will need written authorization and will be charged at normal repair rates. All modifications are to be carried out by OSD technicians. Warranty is void if unauthorized removal and/or tampering with serial number and/or repair labels is evident.

Optical Systems Design Pty. Ltd.
7/1 Vuko Pl. Warriewood 2102
P.O. Box 891 Mona Vale
N.S.W. Australia 2103
Telephone: +61 2 9913 8540
Facsimile: +61 2 9913 8735
Email: osdsales@osd.com.au
Web Site: www.osd.com.au

OPTICAL
SYSTEMS
DESIGN

PTY LTD

A.B.N. 83 003 020 504

Printed in Australia