OPTICAL

SYSTEMS

DESIGN

OPERATOR MANUAL

OSD139A

ASYNCHRONOUS FIBER

OPTIC RS232 MODEM

OPTICAL SYSTEMS DESIGN

OPTICAL SYSTEMS DESIGN

INDEX

1. TECHNICAL SUMMARY.....	4
1.1 BRIEF DESCRIPTION	4
1.1.1 OVERVIEW	4
1.1.2 APPLICATIONS	4
1.1.3 FEATURES AND BENEFITS	4
1.2 TYPICAL CONFIGURATION	5
1.3 PRODUCT OPTIONS	5
1.4 TECHNICAL SPECIFICATIONS.....	6
1.5 PIN ASSIGNMENTS	7
2. INSTALLATION AND OPERATION	8
2.1 INTRODUCTION	8
2.2 INSTALLATION	8
2.2.1 WARNING AND PRECAUTION	8
2.2.2 PACKAGING.....	9
2.2.3 POWER SUPPLY CONNECTIONS.....	9
2.2.4 OTHER CONNECTIONS	10
2.3 OPERATION	10
2.3.1 CONTROLS	10
2.3.2 BLOCK DIAGRAM.....	11
3. MAINTENANCE.....	12
3.1 INTRODUCTION	12
3.2 EXTERNAL INSPECTION	12
3.3 ROUTINE MAINTENANCE.....	12
4. WARRANTY	13
4.1 WARRANTY PERIOD	13
4.2 ALL REPAIRS	13
4.2.1 WARRANTY REPAIRS.....	13
4.2.2 OUT-OF-WARRANTY REPAIRS.....	13
4.2.3 SITE REPAIRS.....	13
4.3 EXCLUSIONS	13
FIGURE 1: TYPICAL CONFIGURATION	5
FIGURE 2: D CONNECTOR PINOUT CONFIGURATION.	7
FIGURE 3: DIMENSIONS	9
FIGURE 4: POWER SOCKET CONNECTION DIAGRAM.....	9
FIGURE 5: DTE/DCE CONTROL	10
FIGURE 6: OSD139 BLOCK DIAGRAM	11
TABLE 1: PRODUCTS AND OPTIONS	5
TABLE 2: TECHNICAL SPECIFICATIONS	6
TABLE 3: PIN ASSIGNMENTS FOR DTE AND DCE MODE	7

1. TECHNICAL SUMMARY

1.1 BRIEF DESCRIPTION

1.1.1 OVERVIEW

The OSD139A is a small, high performance fiber optic modem capable of linking asynchronous RS232 ports (eg: computers, terminals, test equipment etc:) over distances of several kilometres at speeds ranging from DC to 60Kbps.

The OSD139A is available with either a male (OSD139AM) or a female (OSD139AF) 25 Pin D connector. The unit is switchable between DTE/DCE mode (ie: Pin 2 or Pin 3 connects to the optical transmit section of the unit). This is selectable by a toggle switch mounted between the optical connectors.

All units excluding the option L will operate from the data line plus two control lines with standard RS232 line drivers (eg: MC1488 or equivalent) operating from at least $\pm 9V_{DC}$ are employed in the host equipment.

Power in the range of $+6V_{DC}$ to $+12V_{DC}$ may be fed to the unit via Pin 9 of the 25 Pin D connector.

Alternately, $+6V_{DC}$ to $+12V_{DC}$ may be supplied to the unit via the 1.3mm concentric power socket mounted on the side of the OSD139A.

1.1.2 APPLICATIONS

- ▲ Secure communications.
- ▲ Hazardous environments.
- ▲ Factory automation.
- ▲ Long distance synchronous or asynchronous RS232 links.
- ▲ Data transmission through electrically noisy environments.

1.1.3 FEATURES AND BENEFITS

- ▲ Interconnects one RS232/V24 data channel over 3km.
- ▲ Directly plugs into host's RS232 D connector.
- ▲ Complete end to end isolation.
- ▲ DTE or DCE switchable.
- ▲ No user adjustments required.
- ▲ More secure than copper cables.
- ▲ Small size, low cost, robust and reliable.
- ▲ Full duplex asynchronous data transmission at up to 60kbps.
- ▲ Safe transmission in hazardous environments.
- ▲ Available with either male or female D connector.

OPTICAL SYSTEMS DESIGN

1.2 TYPICAL CONFIGURATION

Figure 1 below shows a typical set-up for two OSD139A's that may be used together.

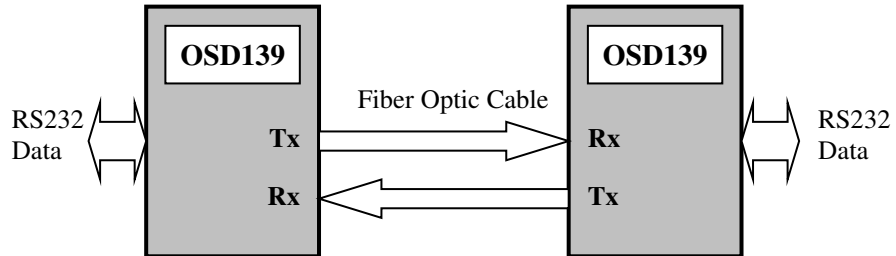

FIGURE 1: TYPICAL CONFIGURATION

1.3 PRODUCT OPTIONS

There are various options available for the OSD139A as indicated below in Table 1.

TABLE 1: PRODUCTS AND OPTIONS

ITEM	DESCRIPTION
OSD139AF	ASYNCHRONOUS RS232 MODEM (FEMALE CONNECTOR)
OSD139AM	ASYNCHRONOUS RS232 MODEM (MALE CONNECTOR)
OPTION L	SINGLEMODE VERSION OF EITHER OF THE ABOVE (REQUIRES OSD139APP)
OSD139APP	PLUG PACK FOR THE OSD139A
OSD139MB	MOUNTING BRACKET FOR THE OSD139A

OPTICAL SYSTEMS DESIGN

1.4 TECHNICAL SPECIFICATIONS

Table 2 below provides the Technical Specifications for the OSD139A.

TABLE 2: TECHNICAL SPECIFICATIONS

SPECIFICATION	PERFORMANCE
Data Supported	RS232 signals (asynchronous)
Data Rate	DC to 60kbps asynchronous
Pulse Distortion	<±5µS over full dynamic range
Transmit Optical Power	-25 to -19dBm peak into multimode fiber (OSD139A only) -25 to -15dBm peak into singlemode fiber (OSD139AL only)
Receiver Sensitivity	< - 47dBm peak for 10 ⁻⁹ Bit Error Rate
Optical Link Budget	> 22dB at 850nm (>6km of multimode fiber) > 22dB at 1310nm (>50km of singlemode fiber)
Receiver Saturation	> - 15dBm peak
Optical Wavelength	850nm nominal (1310nm for OSD139AL)
Optical Connector	ST
Electrical Connector	25 pin female D subminiature (specify Male or Female)
Electrical Output	> ±3V from 600Ω source
DTE/DCE modes	Switch selectable
Powering	Derived from Transmit Data Line plus two control lines when host utilises 1488 type line drivers operating from 9V supplies. Will usually operate off transmit data line alone if driver operates off 12V. Alternately, + 6V to + 12V power can be supplied via Pin 9 or via the power connector. Current is <10mA
Power Connector	1.3mm socket on side of case
Enclosure	Seam welded metal case
Dimensions (mm)	15H X 44W X 80D (excluding connectors)
Operating temperature	-20 to +75°C
Relative humidity	0 to 95% non-condensing

10213905

OPTICAL SYSTEMS DESIGN

1.5 PIN ASSIGNMENTS

Table 3 and Figure 2 below identifies the pin assignments of the 25 Pin D connector on the OSD139A. Shielded cables are recommended for all data wiring.

TABLE 3: PIN ASSIGNMENTS FOR DTE AND DCE MODE

PIN	NAME	DTE FUNCTION	DCE FUNCTION
Pin 1	Case ground	AC coupled to signal ground	
Pin 2	Transmit data	Modem accepts data	Modem outputs data
Pin 3	Receive data	Modem outputs data	Modem accepts data
Pin 4	Request to send	Connected to Pin 5	
Pin 5	Clear to send	Connected to Pin 4	
Pin 6	Data set ready	Connected to Pin 20	
Pin 7	Signal ground	0V ground	
Pin 8	Received line signal detect	Connected to Pin 20	
Pin 9	Power	External +6V _{DC} to +12V _{DC} power may be fed to the modem via this Pin if the host equipment uses non standard RS232 line drivers. Use Pin 7 for 0V ground.	
Pin 20	Data terminal ready	Connected to Pin 6	



FIGURE 2: D CONNECTOR PINOUT CONFIGURATION.
(a) Female Connector, (b) Male Connector

2. INSTALLATION AND OPERATION

2.1 INTRODUCTION

This section outlines the methods required to install and operate the OSD139A successfully. This information should be studied carefully if damage to the equipment or poor results are to be avoided.

This equipment has been fully tested prior to dispatch and is ready for immediate operation. However, it is advisable to check for external transportation damage prior to operation. If damage is detectable, return the unit and the packaging to the supplier.

2.2 INSTALLATION

2.2.1 WARNING AND PRECAUTION

▲ ELECTROMAGNETIC COMPATIBILITY

This is a Class B product.

▲ OPTICAL OUTPUT OPERATION

WARNING: Laser Safety: Class 1 Laser Product per IEC/EN 60825-1:20011 standard.

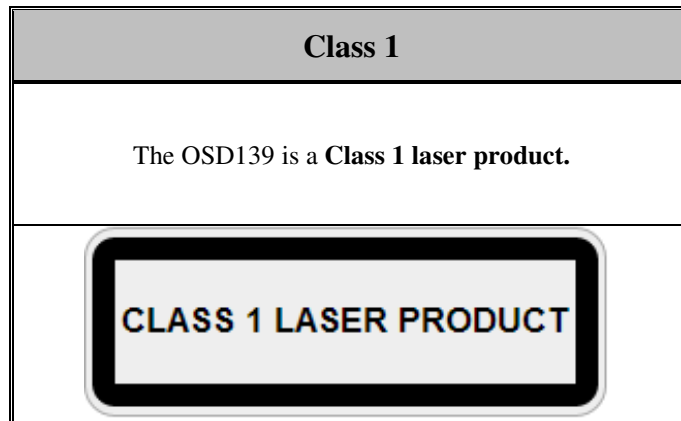

PRECAUTIONS

- ▲ All service personnel should be provided training as to the hazards of direct viewing of laser radiation and of the precautionary measures during servicing of equipment
- ▲ Areas where laser products are installed should be restricted in access to trained service personnel only and appropriate warning signs posted in the work area.
- ▲ All laser apertures should be covered by protective covers when not connected to optical fibers. Never leave outputs uncovered.
- ▲ Laser equipment should be positioned above or below eye level where possible. Apertures should be positioned away from personnel.
- ▲ Protective eyewear should be worn in the vicinity of laser equipment.

OPTICAL SYSTEMS DESIGN

2.2.2 PACKAGING

The case of the OSD139A is made from metal, and is designed to be placed on a bench or to be mounted directly on the host equipment's 25 Pin D connector. Figure 3 below, provides the dimensions of the OSD139A.

OSD can provide a mounting bracket (OSD139MB) as an accessory if required.

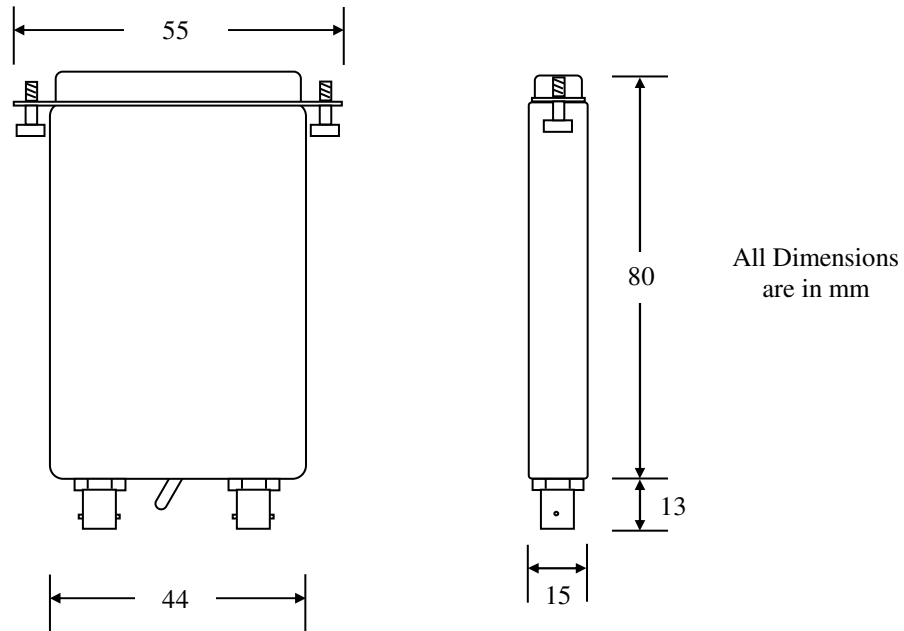

FIGURE 3: DIMENSIONS

2.2.3 POWER SUPPLY CONNECTIONS

Normally the OSD139A will not need to make use of an external power source. +6V_{DC} to +12V_{DC} power may be supplied to the unit via Pin 9 of the 25 Pin D connector if non-standard RS232 drivers are employed in the host equipment or, alternatively, via the external power socket, making use of the OSD139APP. The internal pin is the positive connection and the outer connection is Ground (see Figure 4).

PLEASE NOTE: The OSD139AL *must* be externally powered in either of the two ways described above.

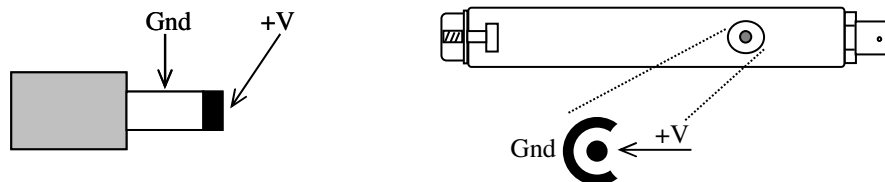

FIGURE 4: POWER SOCKET CONNECTION DIAGRAM

OPTICAL SYSTEMS DESIGN

2.2.4 OTHER CONNECTIONS

The RS232 signals are connected to or from the external equipment as required via the 25 Pin D connector of the OSD139A. Table 3 identifies the connections for the OSD139A configured in both the DTE and DCE modes.

As previously stated, if necessary +6V_{DC} to +12V_{DC} power may be fed to the unit via Pin 9 of the 25 Pin D connector.

The optical fiber should be terminated with the appropriate optical connectors. Before connection, inspect the end of the optical connectors to ensure that no dust or dirt is present as it could contaminate the modem connector and result in poor and degraded performance.

If it is necessary to clean the cable connectors, use isopropyl alcohol with a lint free tissue to remove any contamination.

2.3 OPERATION

2.3.1 CONTROLS

The OSD139A has only one control: the DTE/DCE switch located between the optical connectors. This switch changes the OSD139A between DTE and DCE modes.

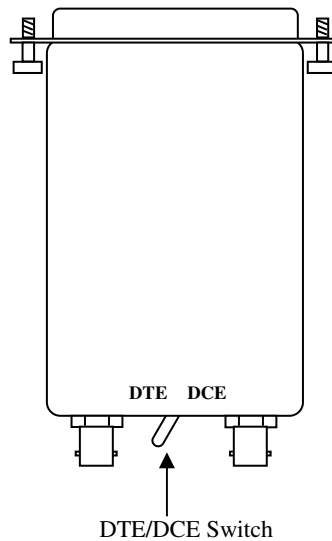

FIGURE 5: DTE/DCE CONTROL

When the units are connected to a DTE host, the transmitting signal is on Pin 2 of the connector (data into the modem) and the received signal is output by the modem on Pin 3 (data out from the modem).

The converse applies to a DCE host.

The pin differences between these two modes are detailed in section 1.5 PIN ASSIGNMENTS (page 7)

OPTICAL SYSTEMS DESIGN

2.3.2 BLOCK DIAGRAM

Figure 6 below is a simple block diagram of the OSD139A.

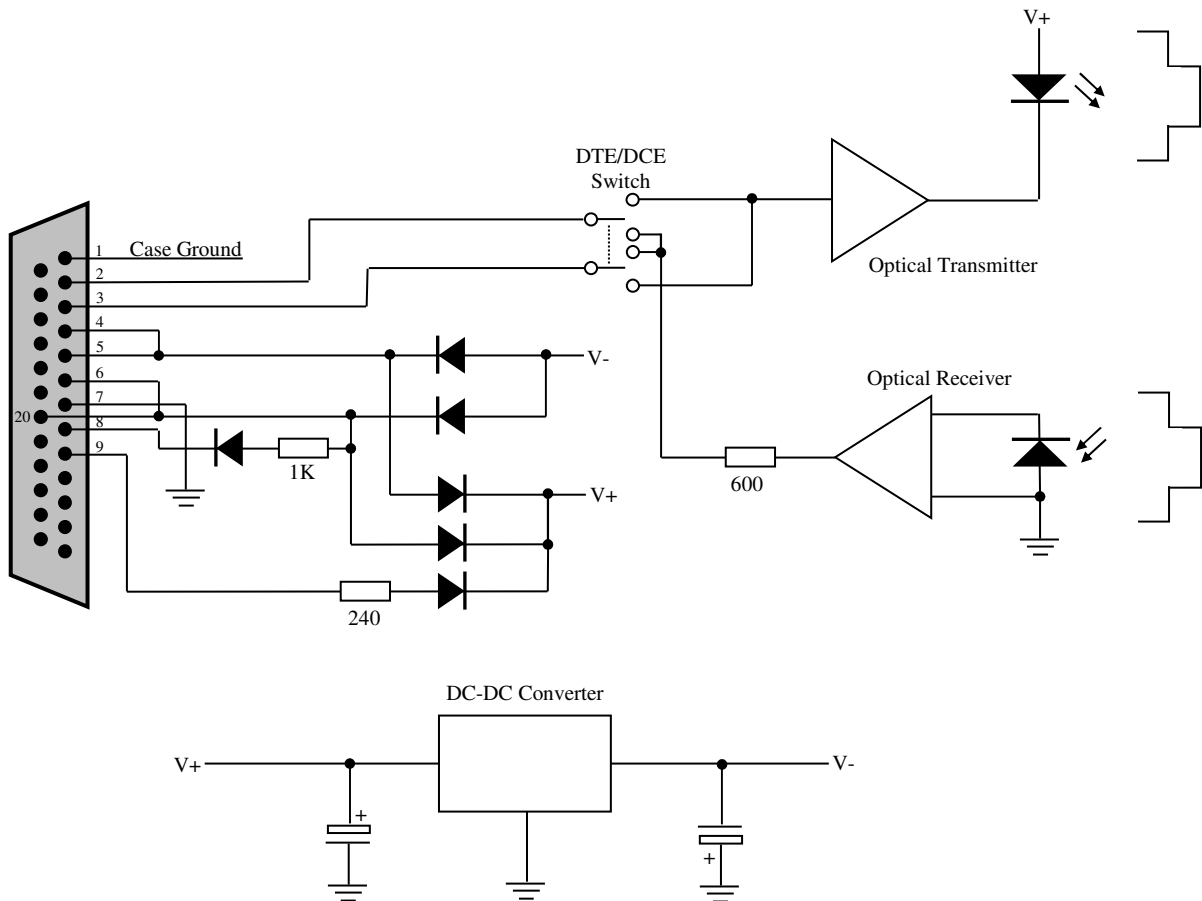

FIGURE 6: OSD139 BLOCK DIAGRAM

3. MAINTENANCE

3.1 INTRODUCTION

The following section outlines the fault-finding procedure for the OSD139A modem. Please take note of the following:

- ▲ Personnel without appropriate training should not attempt any maintenance except that outlined below.
- ▲ If further maintenance is attempted you are warned that every care should be taken to ensure that internal measurements made while the equipment is operational are taken carefully as some components within the unit are expensive and may be damaged by failure of any portion of their support circuitry.
- ▲ Some components within the unit are electrostatic sensitive and ESD precautions should be taken when performing maintenance upon the unit.

3.2 EXTERNAL INSPECTION

Visually check for the following:

- ▲ Ensure that the RS232 signal is connected to the modem correctly and that the distant OSD139A modem has been terminated correctly to any external equipment.
- ▲ Inspect the optical connectors for any contamination and clean using acetone and a lint free tissue if any contamination is detected.
- ▲ Ensure that the DTE/DCE switch is set for the correct mode of operation.

3.3 ROUTINE MAINTENANCE

There is no routine maintenance required with the OSD139A.

4. WARRANTY

Thank you for purchasing equipment designed, manufactured and serviced by Optical Systems Design (OSD). OSD warrants that at the time of shipment, its products are free from defects in material and workmanship and conforms to specifications. Our Warranty conditions are outlined below:

4.1 WARRANTY PERIOD

For warranty period, please call your local OSD distributor.

4.2 ALL REPAIRS

Optical Systems Design reserves the right to repair or replace faulty modules/units. Please obtain a "Return Material Authorisation" number form and number before returning goods. Goods must be returned to Optical Systems Design, Warriewood or its nominated authorised representative, for all repairs in adequate packing material.

4.2.1 WARRANTY REPAIRS

Return shipments to OSD shall be at customer's expense and freight back to the customer will be at OSD expense.

4.2.2 OUT-OF-WARRANTY REPAIRS

OSD reserves the right to repair or replace any faulty goods. Freight costs and insurance for both journeys are met by the user. All equipment repaired by OSD will have a 3 Month Warranty from the date of dispatch.

4.2.3 SITE REPAIRS

By agreement site repairs may be undertaken for which out of pocket, hotel and travel expenses will be charged.

4.3 EXCLUSIONS

This warranty does not apply to defects caused by unauthorised modifications, misuse, abuse or transport damage to the equipment. All modifications to OSD's standard product will need written authorisation and will be charged at normal repair rates. All modifications are to be carried out by OSD Technicians. Warranty will lapse if unauthorised removal and/or tampering with serial number and/or repair labels occurs.

OPTICAL SYSTEMS DESIGN

OPTICAL SYSTEMS DESIGN

Optical Systems Design Pty. Ltd.
7/1 Vuko Pl. Warriewood 2102
P.O. Box 891 Mona Vale
N.S.W. Australia 2103
Telephone: +61 2 9913 8540
Facsimile: +61 2 9913 8735
Email: osdsales@osd.com.au
Web Site: www.osd.com.au

OPTICAL 

SYSTEMS

DESIGN

PTY LTD

A.B.N. 83 003 020 504

Printed in Australia